

Xylo

M18.03



GIBAM
composit

Xylo

M18.03

La qualità ricercata di atmosfere calde ed accoglienti

Il miglior risultato che si può ottenere nella realizzazione di punti vendita, sta nel ricreare ambienti dall'**atmosfera accogliente** che siano capaci di **coinvolgere il cliente** nell'esperienza di acquisto.

M18.03, grazie ai **materiali dalle finiture ricercate** e alle **grandi doti espositive**, permette di creare soluzioni che vanno ben oltre le normali aspettative.

The sought-after quality of warm and welcoming atmospheres

The best result one can obtain when creating a point of sale is in the shaping of environments whose **welcoming atmosphere** can **engage the client** during the purchasing experience.

M18.03, characterised by **refined finishes** and **great display capacity**, allows to create solutions that give much more than the average.

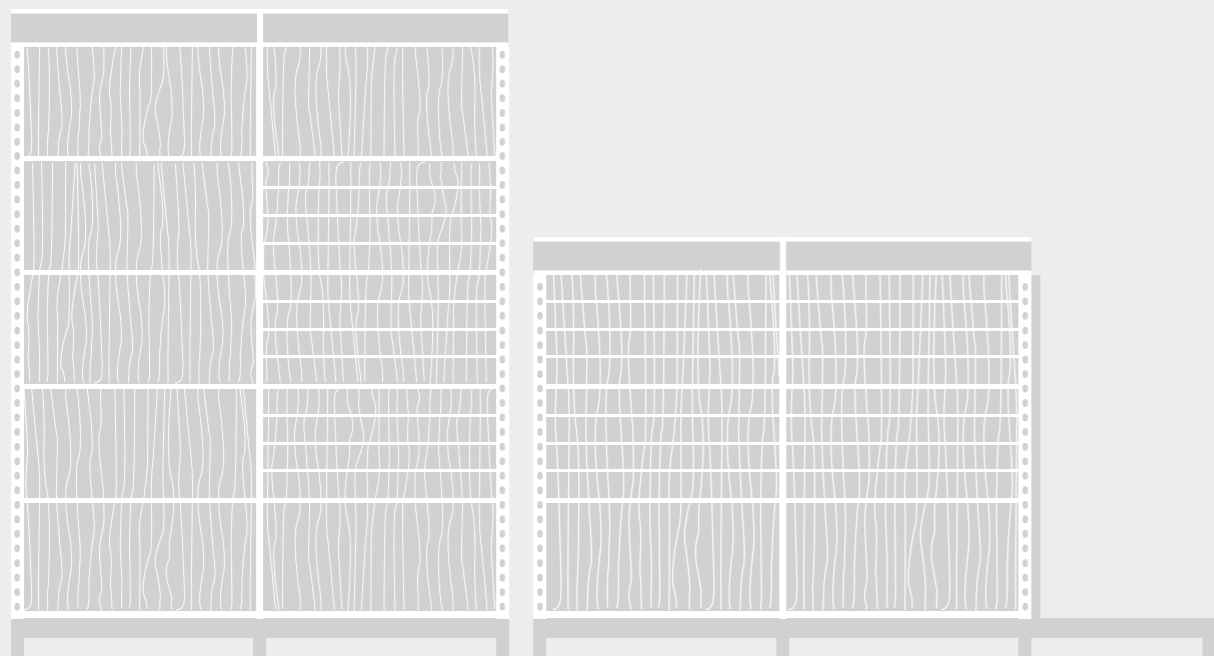

Xylo

M18.03



Il prodotto

Come lo abbiamo progettato [p.06 - 13](#) Come lo vede il cliente [p.14 - 15](#)
Come lo vede l'operatore [p.16 - 17](#) Come comporre M18.03 [p.18 - 31](#)
Come completare M18.03 [p.32 - 47](#) Come vestire M18.03 [p.48 - 61](#)

The product

How we designed it [p.06 - 13](#) How the client sees it [p.14 - 15](#)
How the operator sees it [p.16 - 17](#) How to assemble M18.03 [p.18 - 31](#)
How to complete M18.03 [p.32 - 47](#) How to dress M18.03 [p.48 - 61](#)



creato dalla nostra esperienza created by our experience

M18.03 racchiude in un unico sistema, tutte le migliori qualità di un prodotto pensato per l'allestimento di spazi espositivi dal carattere professionale.

La ricercata natura di ogni singolo dettaglio, mette in evidenza le doti di un prodotto dell'eccellenza italiana, nato dalla nostra esperienza e dalla passione che ci caratterizza da oltre 40 anni.

M18.03 encases into one system all the best qualities of a product devised to create professional display environments.

The refined nature of every detail puts into evidence the peculiarities of a product of Italian excellence, born from our experience and from the passion that characterises us since over 40 years.

una scenografia espositiva a display scenography

L'atmosfera intensa, ricreata dalla qualità degli spazi espositivi di M18.03, conferisce all'esperienza di acquisto un nuovo punto di vista e una maggiore importanza. La parete espositiva, si trasforma in una scenografia capace di emozionare l'utente con ricercate essenze del legno, vetri dalle raffinate trasparenze, e una completa gamma di colori perfettamente studiati per completare le composizioni. Tutti gli accessori sono studiati per dare risposta alle più complesse esigenze di visual merchandising rendendo M18.03 un prodotto adatto a molteplici categorie merceologiche.

The intense atmosphere created by the quality of the display spaces made with M18.03, confers to the purchasing quality a new perspective and a greater importance. The wall display is transformed into a scenography that conveys a feeling to the client, thanks to refined wood finishes, glasses, and a colour palette that matches all compositions. The accessories are devised to be an answer to the most complex visual merchandising needs, thus making of M18.03 a product suitable to many product categories.



estetica funzionale functional aesthetics

Le qualità espositive della linea M18.03, sono facilmente percepibili già dal primo impatto estetico all'interno dell'ambiente.

La struttura, così come gli accessori, nascono da un design ricercato, che ha lo scopo di valorizzare il prodotto e l'esposizione. L'eleganza ordinata delle composizioni è di facile approccio al cliente, ma allo stesso tempo conserva grandi doti di funzionalità e di adattabilità, necessarie per l'operatore.

The display features of M18.03 are easily perceived at first sight. Its structure as well as its accessories are the result of a refined design effort, aimed at giving extra value to the product and the display.

The well-ordained elegance of its compositions is easily approached by the client, yet it preserves a great functionality and adjustability, as the operator needs.





accessori luminosi pratici e raffinati practical and refined accessories with light

La struttura di M18.03 è studiata per abbinarsi ai profili elettrificati, che permettono di alimentare tutti gli accessori luminosi presenti nella serie. La luce resta perfettamente integrata nei ripiani in legno e in vetro, mantenendo il design funzionale, pulito e coerente.

La capacità di valorizzare l'esposizione dei prodotti e di creare piacevoli effetti di ambientazione, sono una caratteristica fondamentale nella realizzazione di punti vendita di elevato livello professionale.

The structure of M18.03 includes electrified profiles, making possible to use accessories with embedded light fixtures. The light fixtures are thus part of wood and glass shelves, so to keep the design functional, clean and coherent. The capacity to enhance the product's display and to create pleasant environment effects is a basic characteristics of the creation of highly professional points of sale.

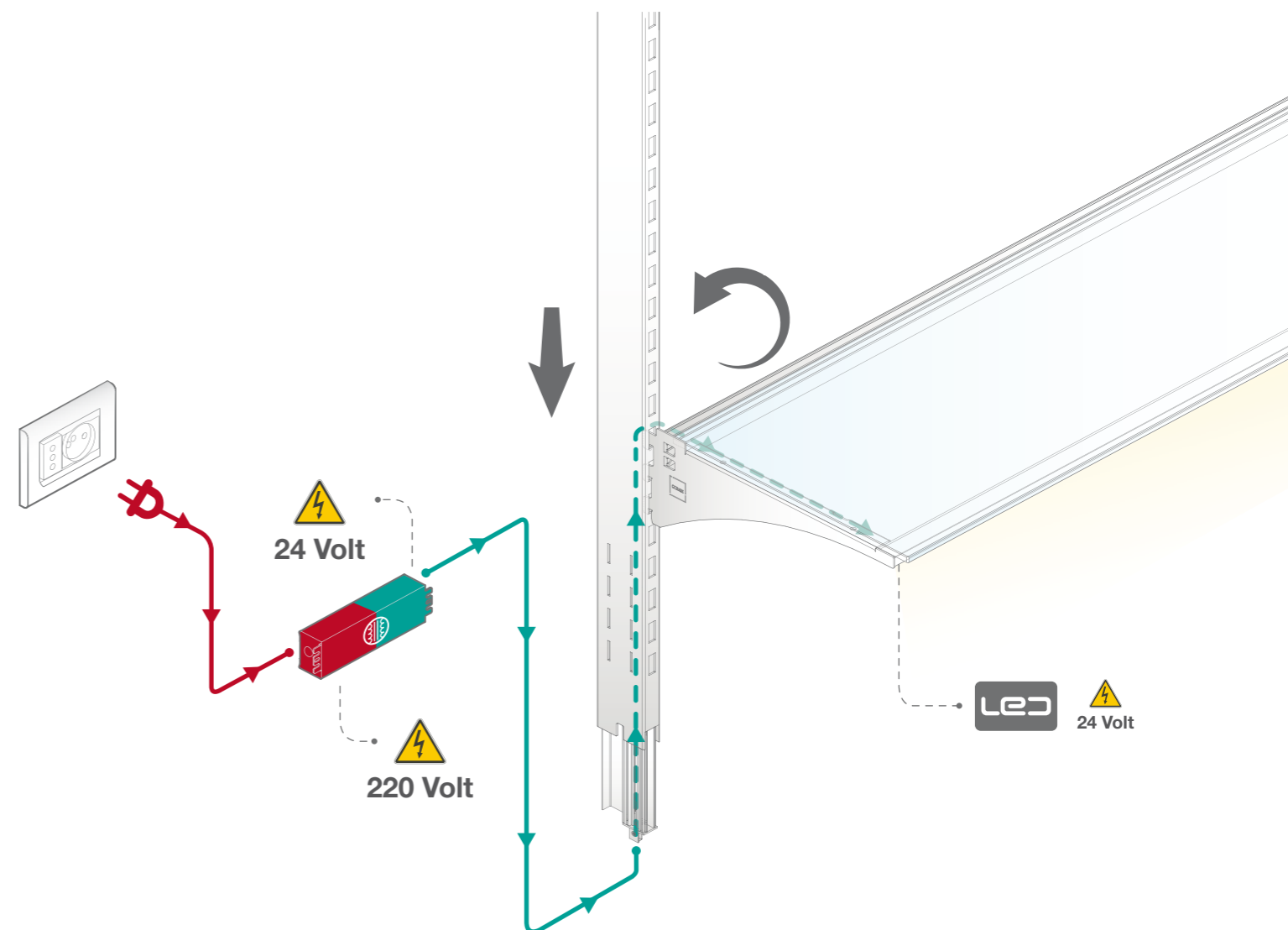

M
sit



teccos
italian wall

GIBAM

Italian Wallcoverings
collection is the new
way to decorate your
space.
This collection
collection is made up
of 6 type of supports:
■ Natural Succo
■ Natural Canvas
■ TNT
■ Seta
■ Precious
■ H2O
www.gibam.com

M18.03 essenza della perfezione M18.03 essence of perfection

COME LO VEDE IL CLIENTE HOW THE CLIENT SEES IT

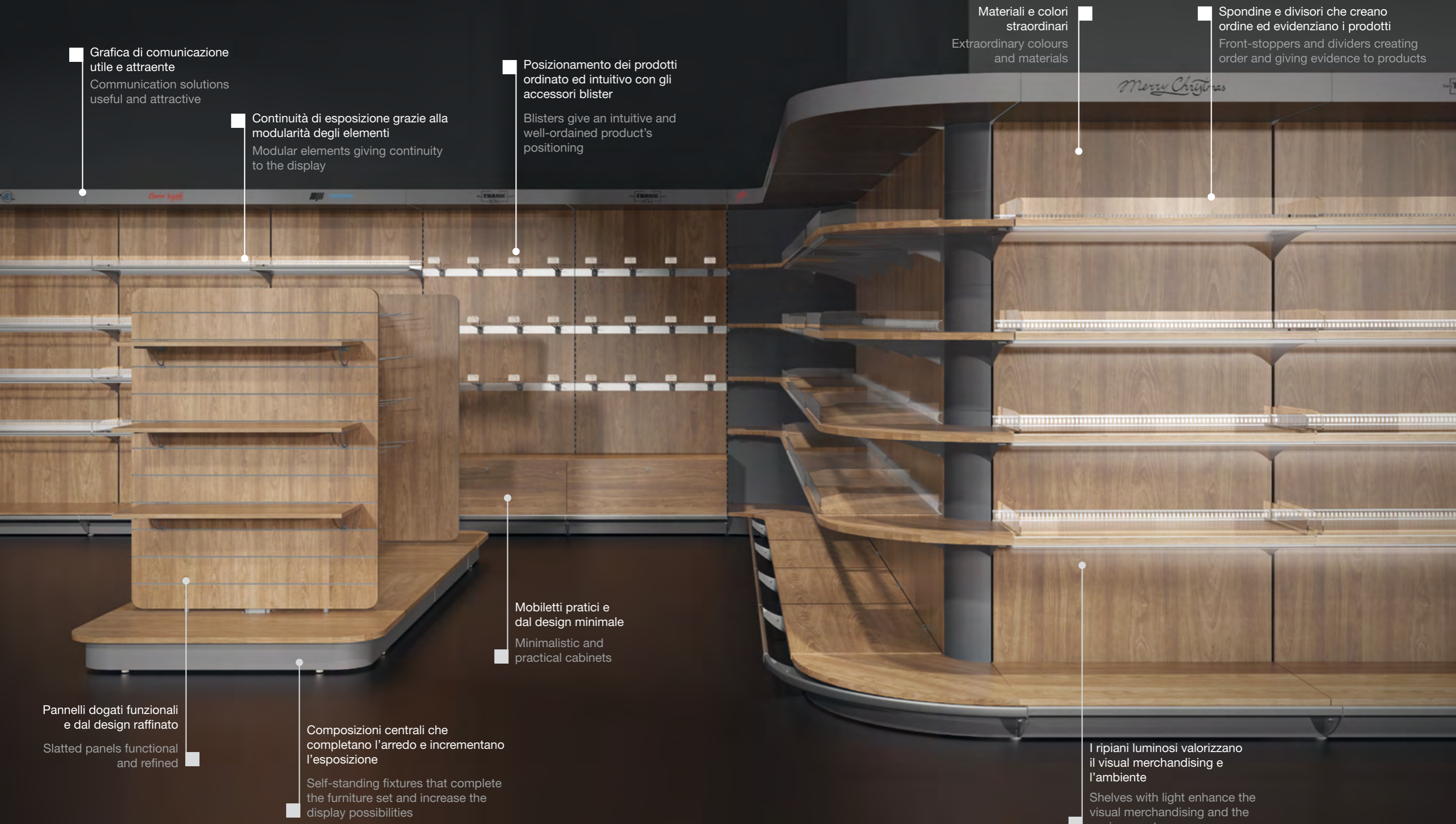

Grafica di comunicazione utile e attraente
Communication solutions useful and attractive

Continuità di esposizione grazie alla modularità degli elementi
Modular elements giving continuity to the display

Posizionamento dei prodotti ordinato ed intuitivo con gli accessori blister
Blisters give an intuitive and well-ordained product's positioning

Materiali e colori straordinari
Extraordinary colours and materials

Spondine e divisori che creano ordine ed evidenziano i prodotti
Front-stoppers and dividers creating order and giving evidence to products

Pannelli dogati funzionali e dal design raffinato
Slatted panels functional and refined

Composizioni centrali che completano l'arredo e incrementano l'esposizione
Self-standing fixtures that complete the furniture set and increase the display possibilities

Mobiletti pratici e dal design minimale
Minimalistic and practical cabinets

I ripiani luminosi valorizzano il visual merchandising e l'ambiente
Shelves with light enhance the visual merchandising and the environment

M18.03 efficiente in ogni situazione

M18.03 efficient in every situation

COME LO VEDE L'OPERATORE

HOW THE OPERATOR SEES IT

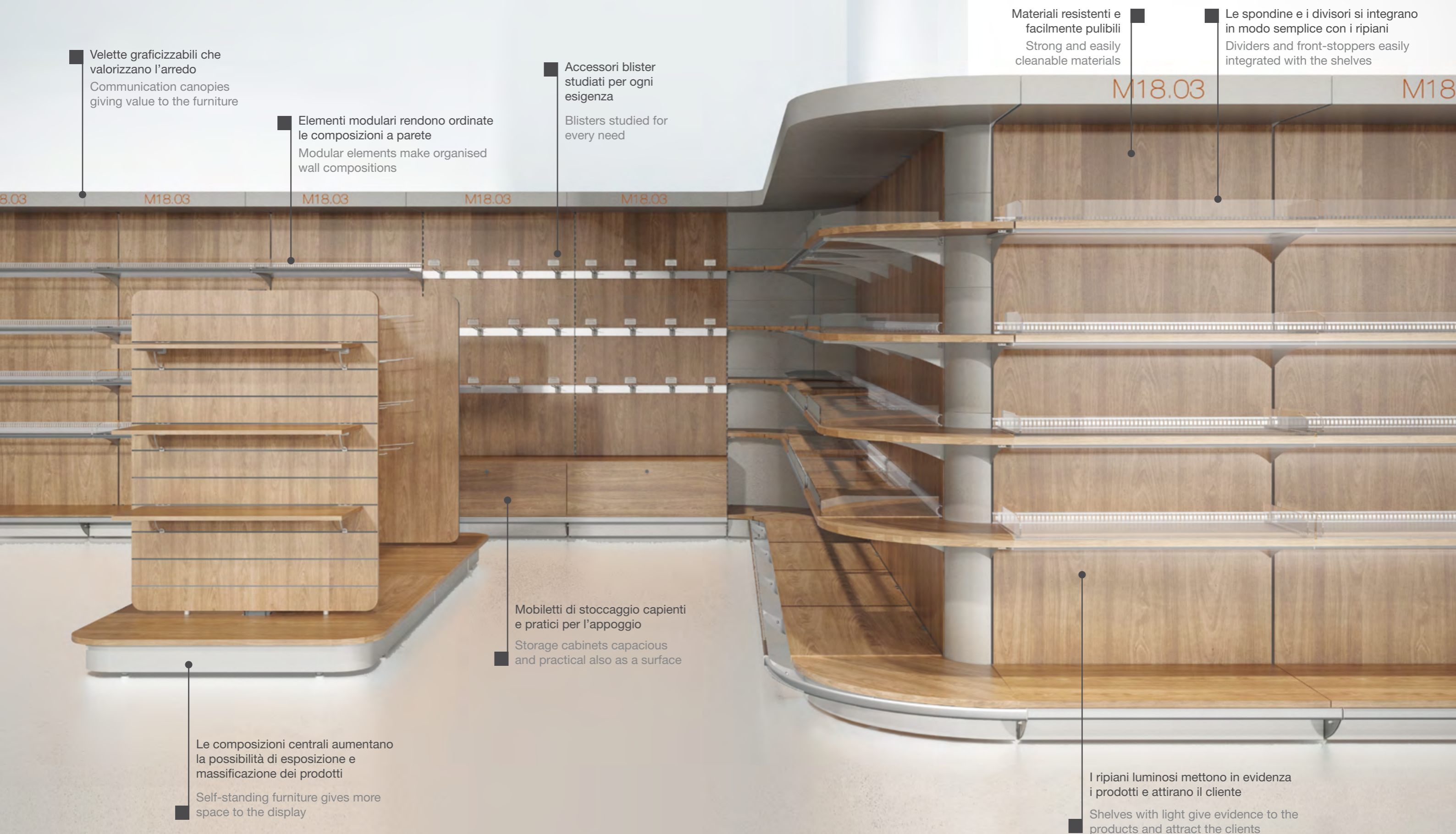

Velette graficizzabili che valorizzano l'arredo
Communication canopies giving value to the furniture

Elementi modulari rendono ordinate le composizioni a parete
Modular elements make organised wall compositions

Accessori blister studiati per ogni esigenza
Blisters studied for every need

Materiali resistenti e facilmente pulibili
Strong and easily cleanable materials

Le spondine e i divisori si integrano in modo semplice con i ripiani
Dividers and front-stoppers easily integrated with the shelves

M18.03

M18

Mobiletti di stoccaggio capienti e pratici per l'appoggio
Storage cabinets capacious and practical also as a surface

Le composizioni centrali aumentano la possibilità di esposizione e massificazione dei prodotti

Self-standing furniture gives more space to the display

I ripiani luminosi mettono in evidenza i prodotti e attirano il cliente

Shelves with light give evidence to the products and attract the clients



LA STRUTTURA

M18.03 è una serie realizzata da elementi montanti, sui quali si fissano, in modo continuo, tutti le parti che compongono la struttura. La modularità di questo prodotto, lo rende un sistema versatile, che ha la possibilità di creare sia composizioni da parete che elementi centrali, adattandosi perfettamente all'ambiente e alla tipologia di offerta merceologica.

THE STRUCTURE

M18.03 is a series construed on uprights, onto which are fixed in a continuous way all the other elements of its structure. The modularity of this product is at the core of its versatility, with which one can create wall compositions as well as gondolas, thus being perfectly adjustable to the environment and to the merchandise category.

Perfezione modulare
Modular perfection

Ripiani in legno su reggipiano
Wood shelves on shelf supports

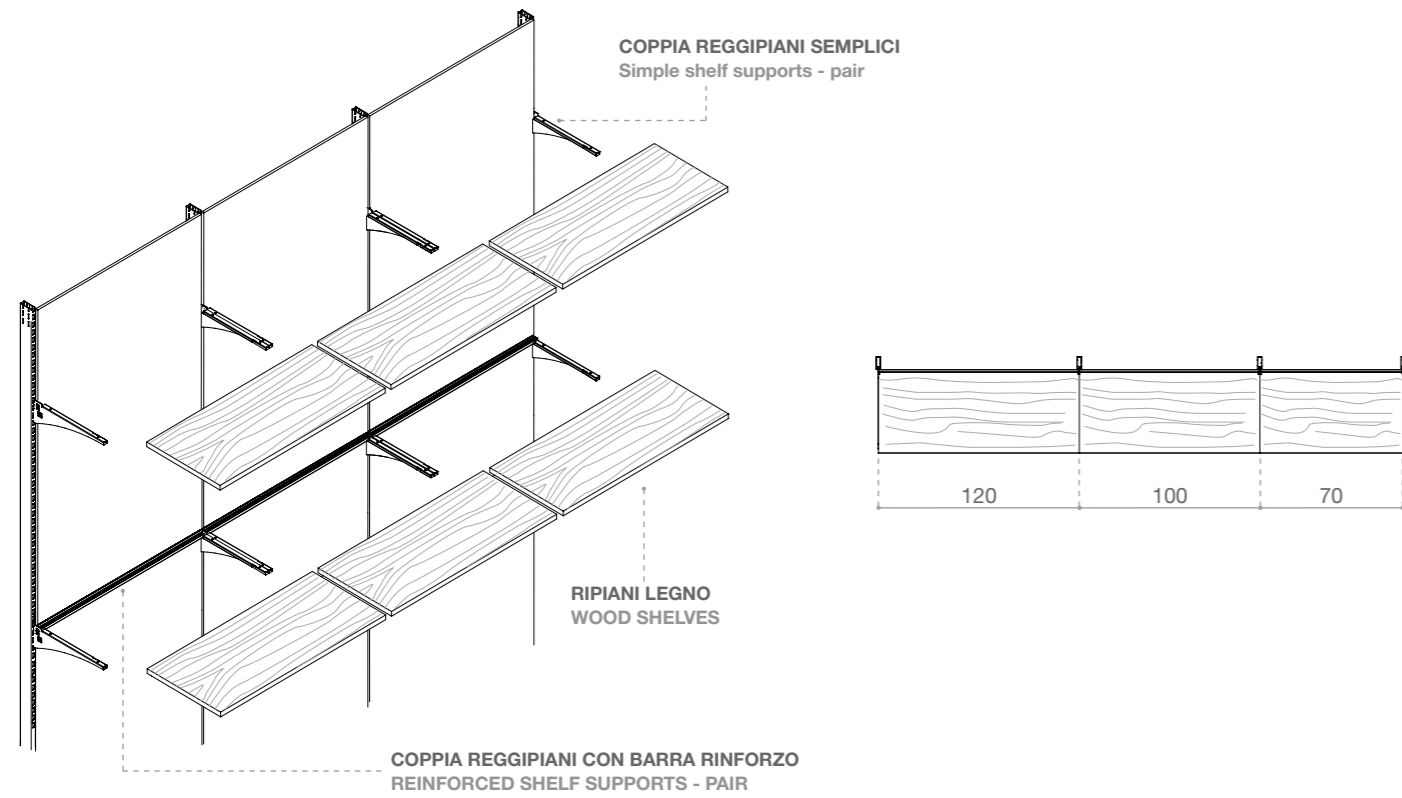

CARICHI PER REGGIPIANI SEMPLICI
LOADS FOR SIMPLE SHELF SUPPORTS

L = passo pitch		P =profondità depth		
		26	36	46
70		20	30	40
100		15	25	35
120		10	20	30

CARICHI PER REGGIPIANI CON BARRA RINFORZO
LOADS FOR REINFORCED SHELF SUPPORTS

L = passo pitch		P =profondità depth		
		26	36	46
70		40	55	65
100		35	50	60
120		30	45	45

Ripiani in vetro su reggipiano
Glass shelves on shelf supports

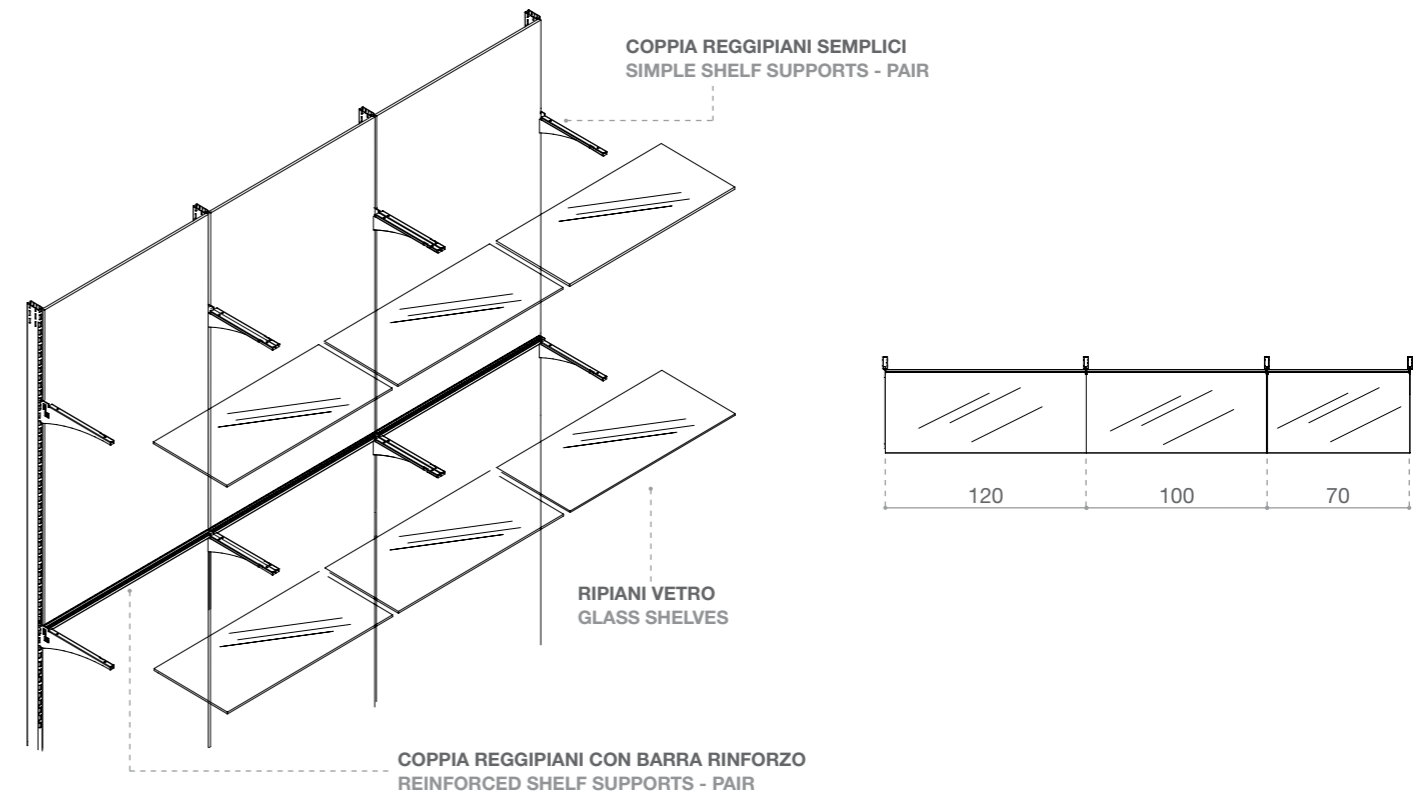

CARICHI PER REGGIPIANI SEMPLICI
LOADS FOR SIMPLE SHELF SUPPORTS

L = passo pitch		P =profondità depth		
		26	36	46
70		15	20	30
100		10	15	25
120		8	13	23

CARICHI PER REGGIPIANI CON BARRA RINFORZO
LOADS FOR REINFORCED SHELF SUPPORTS

L = passo pitch		P =profondità depth		
		26	36	46
70		25	40	45
100		20	35	40
120		15	30	35

A

Montante
Upright

materiali: materials: **A00** **A01** **A02** **A04**

70 x 25 mm

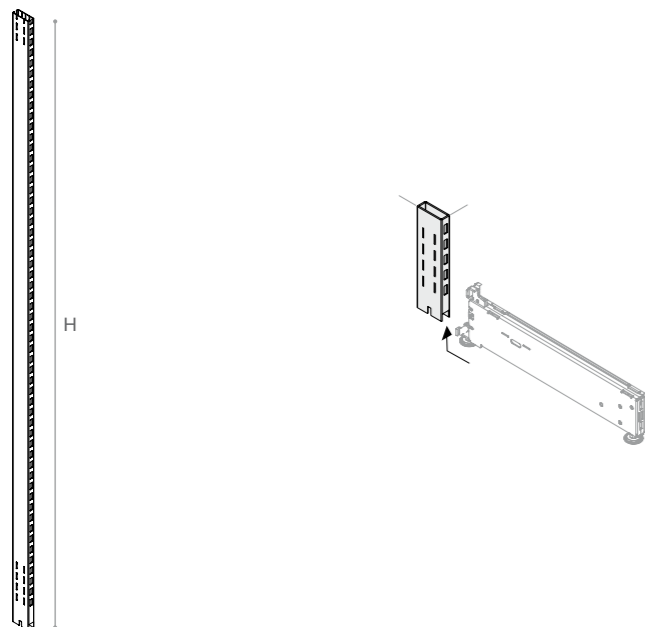

H	codice code
134	7067000
146	7067005
158	7067010
182	7067015
206	7067020
230	7067025
266	7067030
302	7067035

120 x 25 mm

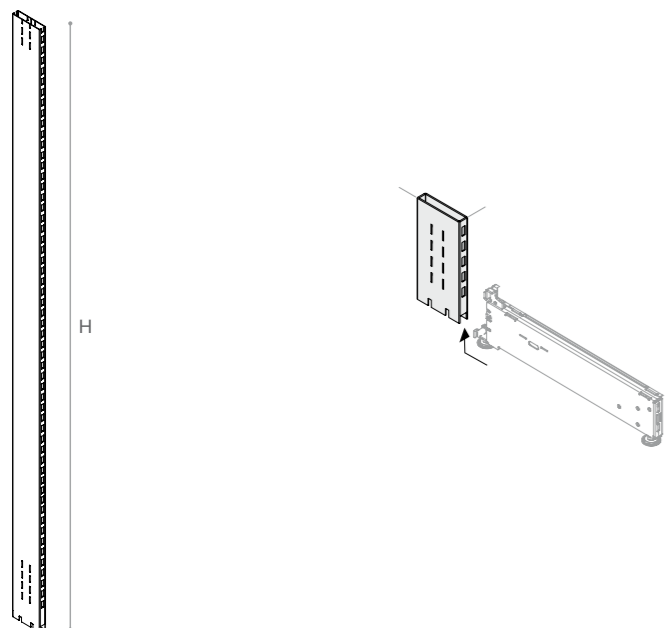

H	codice code
182	7067040
206	7067045
230	7067050
266	7067055
302	7067060

B

Profilo elettrificato
Power profile

materiali: materials: **Z00**



max 120 W
max 120 W

elettrificazione singola 70 x 25 mm
single sided 70 x 25 mm

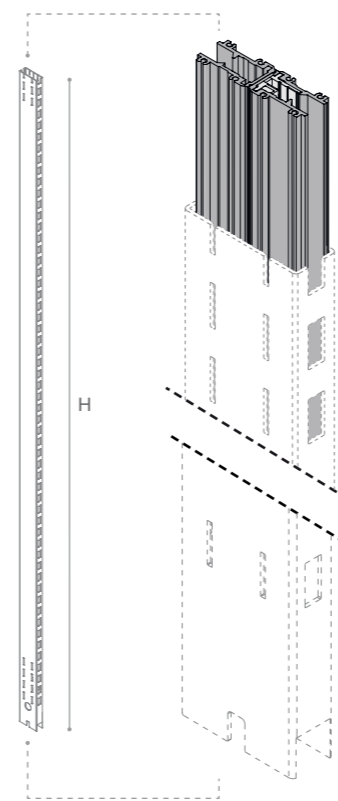

H	⚠	codice code
134	45 W	7089500
146	45 W	7089505
158	75 W	7089510
182	75 W	7089515
206	120 W	7089520
230	120 W	7089525
266	120 W	7089530
302	120 W	7089535

elettrificazione singola 120 x 25 mm
single sided 120 x 25 mm

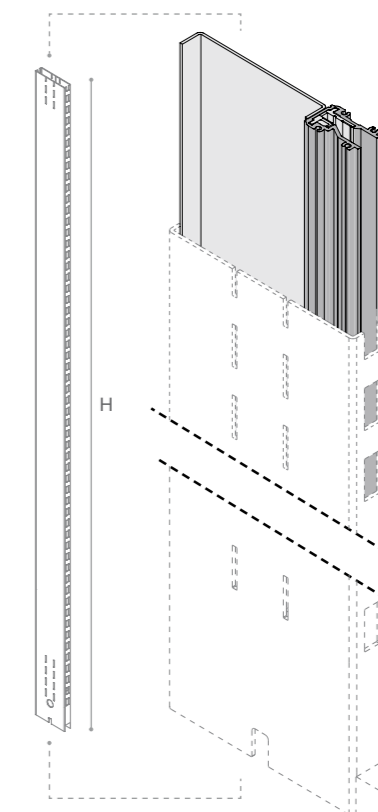

H	⚠	codice code
182	75 W	7089540
206	120 W	7089545
230	120 W	7089550
266	120 W	7089555
302	120 W	7089560

elettrificazione doppia 70 x 25 mm
double sided 70 x 25 mm

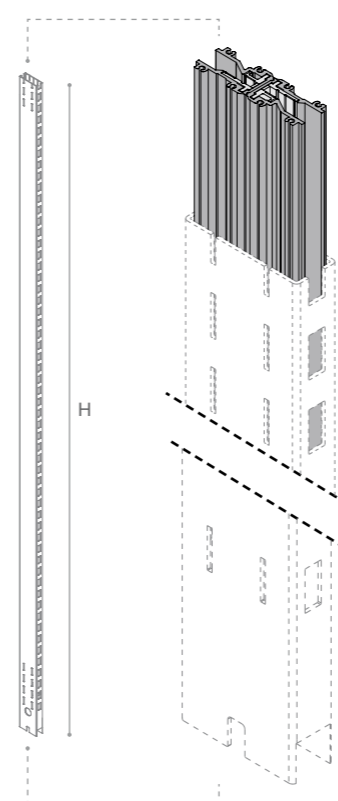

H	⚠	codice code
134	2x45 W	7089565
146	2x45 W	7089570
158	2x75 W	7089575
182	2x75 W	7089580
206	2x120 W	7089585
230	2x120 W	7089590
266	2x120 W	7089595
302	2x120 W	7089600

elettrificazione doppia 120 x 25 mm
double sided 120 x 25 mm

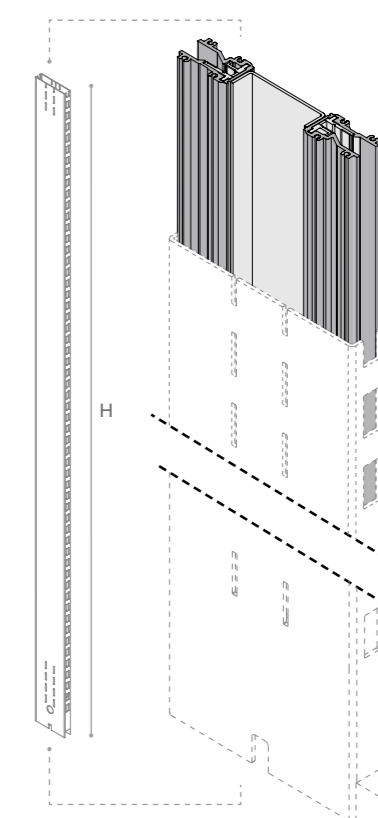

H	⚠	codice code
182	2x75 W	7089605
206	2x120 W	7089610
230	2x120 W	7089615
266	2x120 W	7089620
302	2x120 W	7089625

C Piedino montanti senza piede
Footless uprights leveling foot

materiali: materials: **Z00**

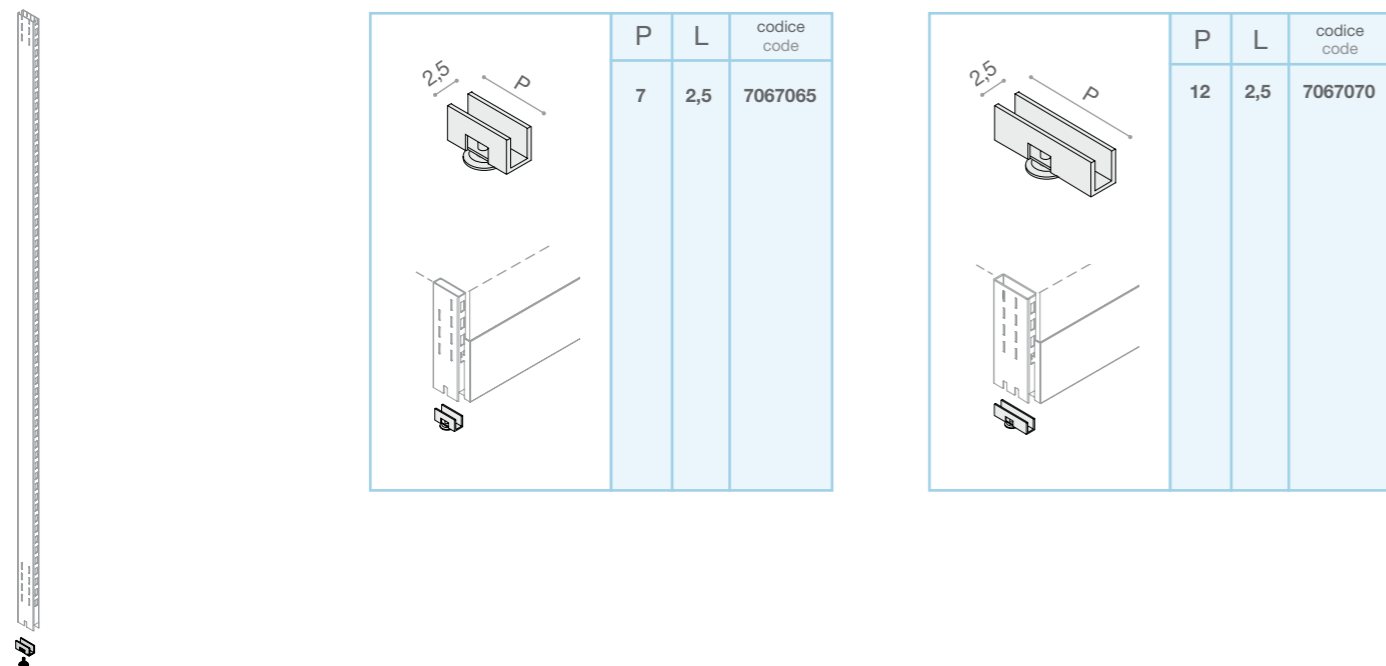

D Staffa fissaggio montanti senza piede
Footless uprights fixing bracket

materiali: materials: **Z00**

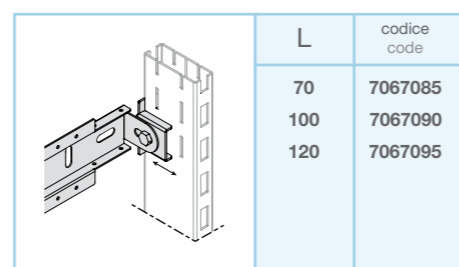
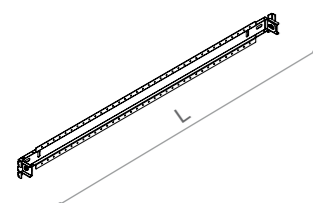

E Fissaggio montanti
Uprights fixing set

materiali: materials: **Z00**

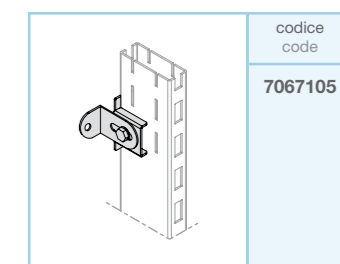

F Staffa telescopica
Telescopic bracket

materiali: materials: **A00***

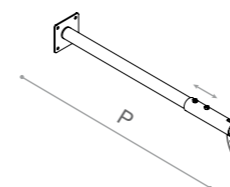

*COLORE UNICO verniciatura a polvere
colore nero 03T.
*ONE COLOUR ONLY powder coating
black 03T.

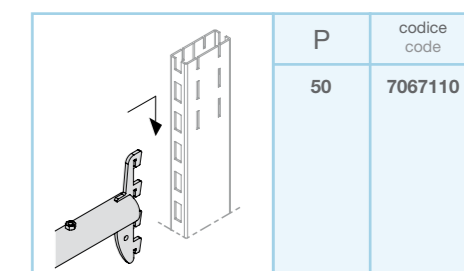

G Tappo montanti
Uprights plug

materiali: materials: **Z00**

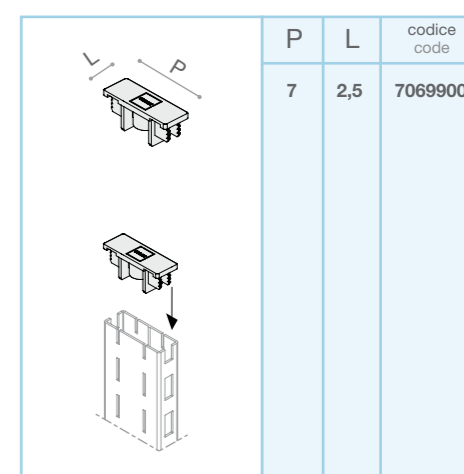

H Piede rettangolare base scatolata
Box-shaped base rectangular foot

materiali: materials: **A00 A01 A02 A04**



Con il piede rettangolare è sempre consigliato l'utilizzo del fissaggio a muro codice 7067105
With the rectangular foot it is always recommended to use the wall fixing set code 7067105

P	codice code
36	7067170
46	7067175
56	7067180

I Finiture piedi rettangolari
Rectangular feet end covers

materiali: materials: **A00 A01 A02 A04**

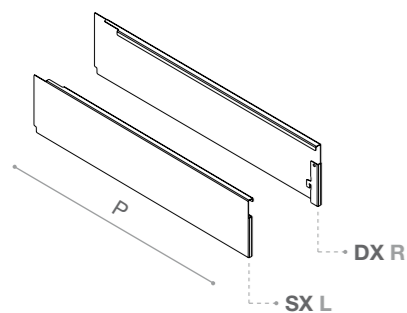

	P	codice code
SX L	36	7090150
SX L	46	7090155
SX L	56	7090160
DX R	36	7069840
DX R	46	7069845
DX R	56	7069850

J Coppia reggipiano piede rettangolare
Rectangular foot shelf supports - pair

materiali: materials: **A00 A01 A02 A04**

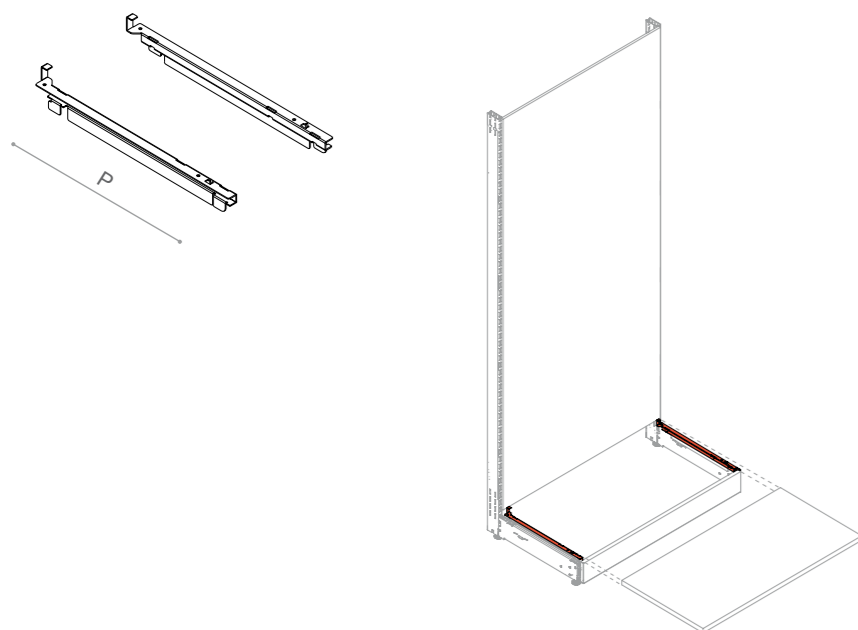

P	codice code
36	7067195
46	7067200
56	7067205

K Zoccolo base scatolata
Box-shaped base skirting

materiali: materials: **A00 A01 A02 A04**

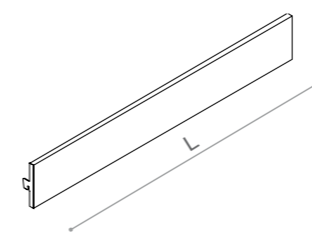

L	codice code
70	7067245
100	7067250
120	7067255

L Zoccolo montanti senza piede
Footless uprights skirting

materiali: materials: **A00 A01 A02 A04**

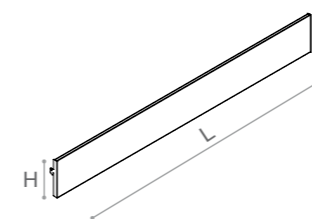

H	L	codice code
14	70	7068010
14	100	7068015
14	120	7068020

M Zoccolo angolo interno 45° base scatolata
Box-shaped base 45° inward corner skirting

materiali: materials: **A00** **A01** **A02** **A04**

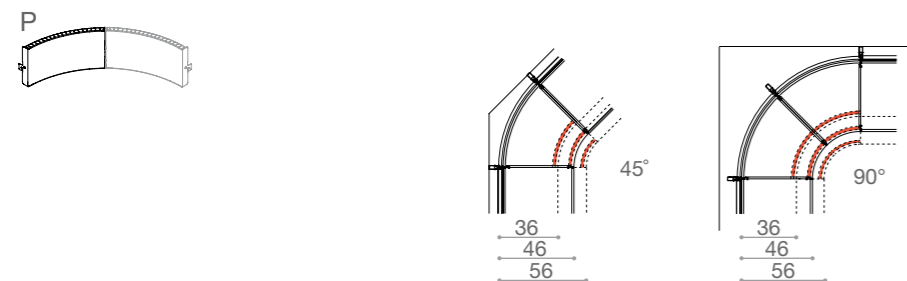

P	codice code
36	7071030
46	7071035
56	7071040

N Zoccolo angolo esterno 90° base scatolata
Box-shaped base 90° outward corner skirting

materiali: materials: **A00** **A01** **A02** **A04**



P	codice code
36	7071230
46	7071235
56	7071240

O Kit barre rinforzo ripiano base legno
Base wooden shelves reinforcing set

materiali: materials: **A00***

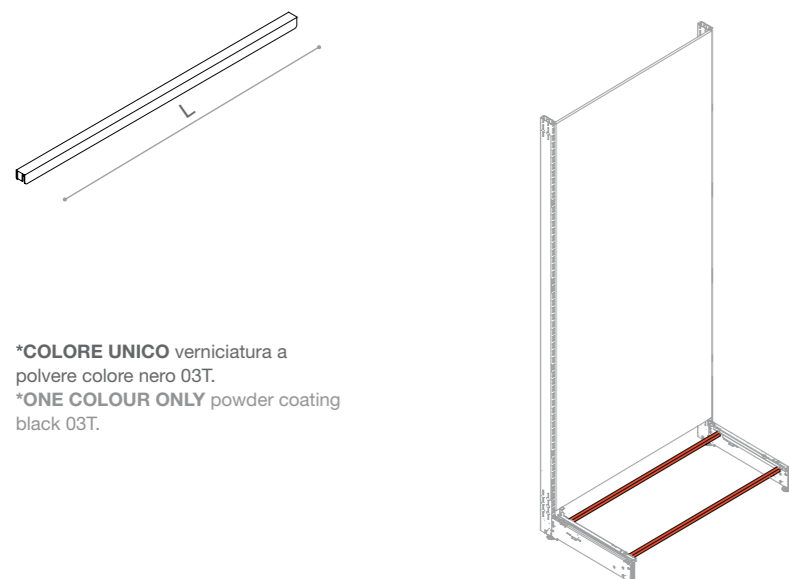

*COLORE UNICO verniciatura a polvere colore nero 03T.
*ONE COLOUR ONLY powder coating black 03T.

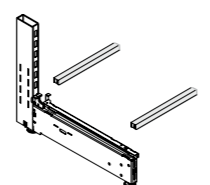

kit 2 barre rinforzo
2 reinforcing rods set

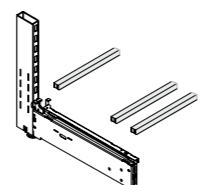

kit 3 barre rinforzo
3 reinforcing rods set

L	codice code
70	7069535
100	7069540
120	7069545
70	7067385
100	7067390
120	7067395

P Ripiano base legno
Base wooden shelf

materiali: materials: **B00** **B01** **B02** **B03** **B04**

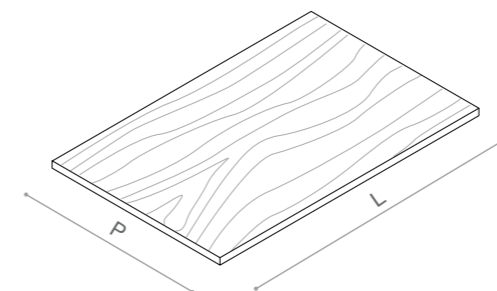

P	L 70	L 100	L 120
	codice code	codice code	codice code
36	7069080	7069085	7069090
46	7069100	7069105	7069110
56	7069120	7069125	7069130

Q Ripiano base angolo interno 45° legno
45° inward corner base wooden shelf

materiali: materials: **B00** **B01** **B02** **B03** **B04**

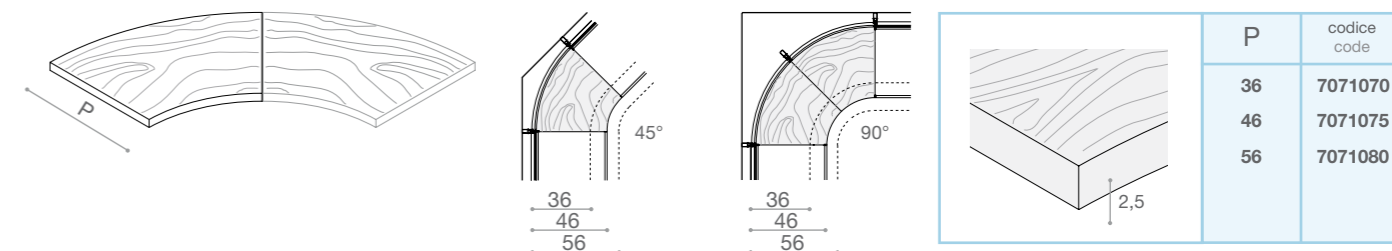

P	codice code
36	7071070
46	7071075
56	7071080

R Ripiano base angolo esterno 90° legno
90° outward corner base wooden shelf

materiali: materials: **B00** **B01** **B02** **B03** **B04**

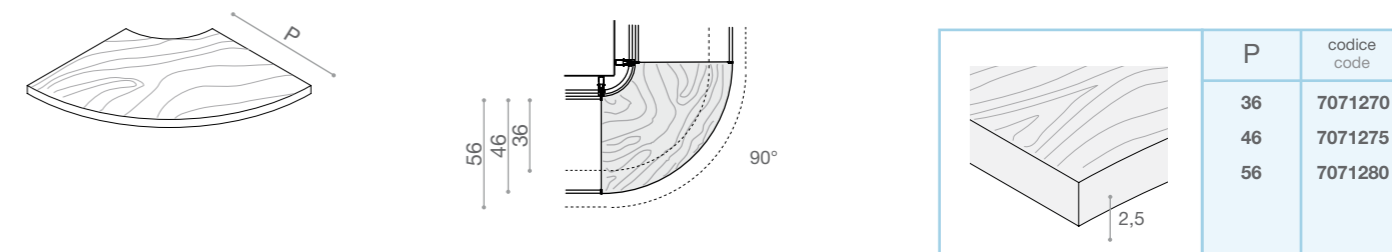

P	codice code
36	7071270
46	7071275
56	7071280

S Pannello legno
Wooden panel

materiali: materials: **B00 B01 B02 B03 B04**

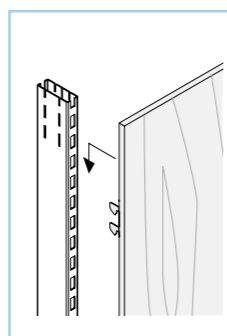
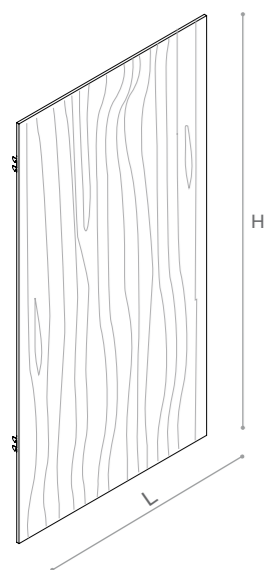

H	L 70	L 100	L 120
	codice code	codice code	codice code
134	7067485	7067490	7067495
146	7067505	7067510	7067515
158	7067525	7067530	7067535
182	7067545	7067550	7067555
206	7067565	7067570	7067575
230	7067585	7067590	7067595
266	7067605	7067610	7067615
302	7067625	7067630	7067635

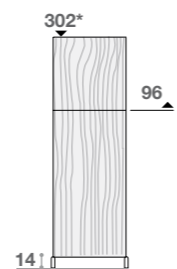
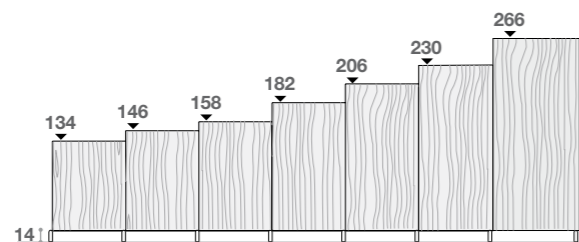

*Il codice del pannello di altezza 302 cm è costituito da 1 pannello di altezza 206 e da 1 pannello aggiuntivo da 96 cm.

*The code of the panel high 302 cm is constituted by 1 panel x 206 cm and 1 additional panel x 96 cm.

T Pannello dogato legno
Wooden slatted panel

materiali: materials: **B00 B01 B02 B03 B04**

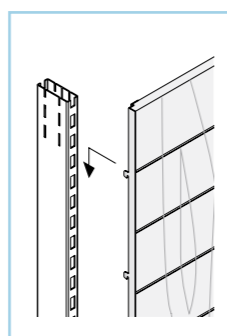
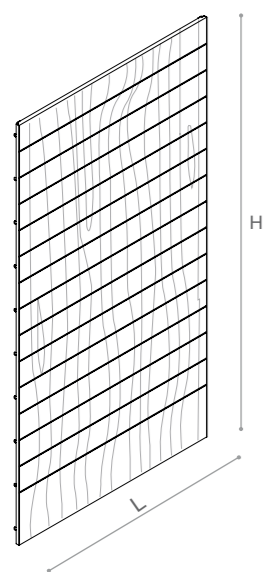

H	L 70	L 100	L 120
	codice code	codice code	codice code
134	7067645	7067650	7067655
146	7067665	7067670	7067675
158	7067685	7067690	7067695
182	7067705	7067710	7067715
206	7067725	7067730	7067735
230	7067745	7067750	7067755
266	7067765	7067770	7067775
302	7067785	7067790	7067795

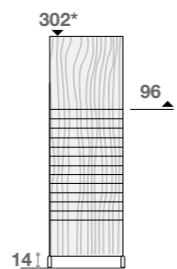
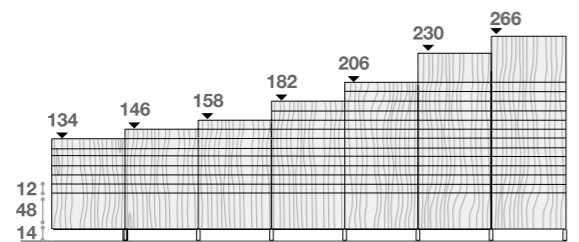

*Il codice del pannello dogato di altezza 302 cm è costituito da 1 pannello di altezza 206 e da 1 pannello aggiuntivo da 96 cm.

*The code of the slatted panel high 302 cm is constituted by 1 panel x 206 cm and 1 additional panel x 96 cm.

U Pannello angolo interno 45° metallo
Metal 45° inward corner panel

materiali: materials: **A00 A01 A02 A04**

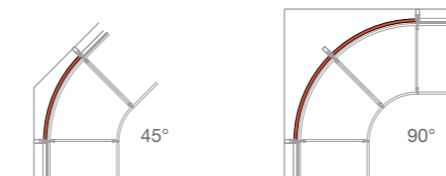
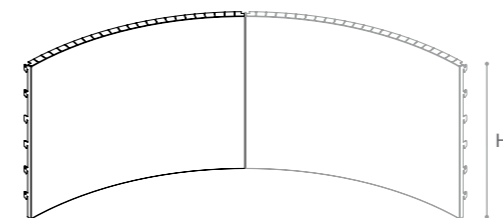

H	codice code
36	7071000
48	7071005



V Pannello angolo esterno 90° metallo
Metal 90° outward corner panel

materiali: materials: **A00 A01 A02 A04**

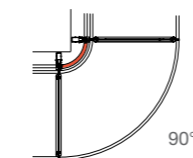
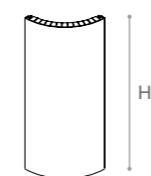

H	codice code
36	7071200
48	7071205

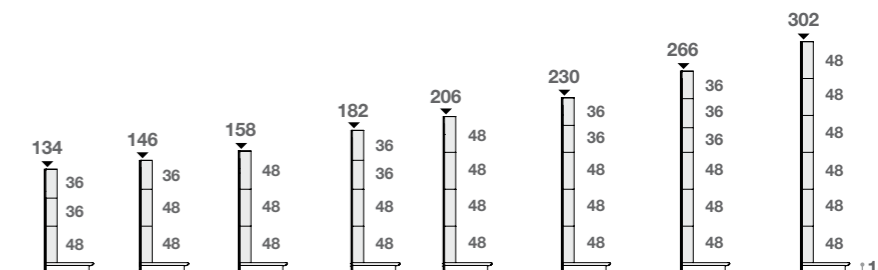

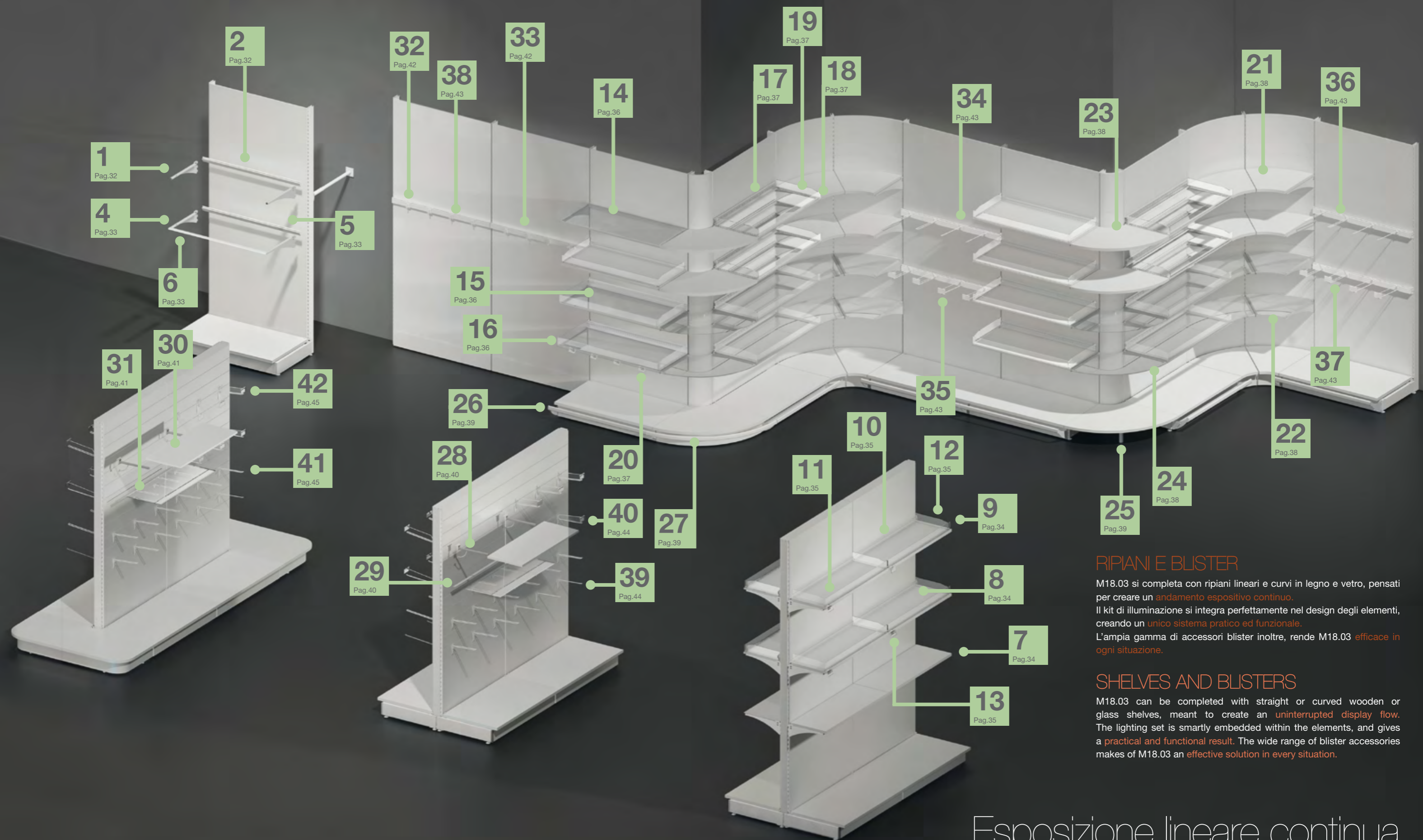

RIPIANI E BLISTER

M18.03 si completa con ripiani lineari e curvi in legno e vetro, pensati per creare un **andamento espositivo continuo**. Il kit di illuminazione si integra perfettamente nel design degli elementi, creando un **unico sistema pratico ed funzionale**. L'ampia gamma di accessori blister inoltre, rende M18.03 **efficace in ogni situazione**.

SHELVES AND BLISTERS

M18.03 can be completed with straight or curved wooden or glass shelves, meant to create an **uninterrupted display flow**. The lighting set is smartly embedded within the elements, and gives a **practical and functional result**. The wide range of blister accessories makes of M18.03 an **effective solution in every situation**.

Esposizione lineare continua
Uninterrupted linear display

1 Coppia reggipiano cremagliera PZ-1 per ripiani legno/vetro
PZ-1 shelf supports for slotted upright panels (pair) - wooden/glass shelves

materiali: materials: **A00 A01 A02 A04**

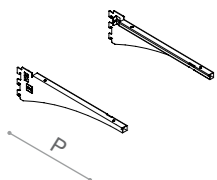

	P	codice code
	26	7090090
	36	7090095
	46	7090100

2 Coppia reggipiano e barra rinforzo ripiani legno/vetro
Wooden and glass shelves reinforced shelf supports - pair

materiali: materials: **A00 A01 A02 A04**

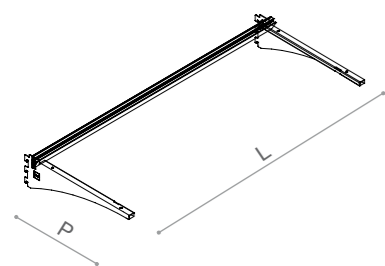

	P	L 70	L 100	L 120
		codice code	codice code	codice code
	26	7090105	7090110	7090115
	36	7090120	7090125	7090130
	46	7090135	7090140	7090145

4 Coppia reggipiano cremagliera PZ-2 per ripiani luminosi legno/vetro
PZ-2 shelf supports for slotted upright panels (pair) - Wooden/glass lit shelves

materiali: materials: **A00 A01 A02 A04**

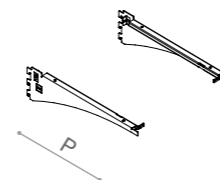

	P	codice code
	26	7089630
	36	7089635
	46	7089640

5 Coppia reggipiano e barra rinforzo ripiani luminosi legno/vetro
Wooden and glass lit shelves reinforced shelf supports - pair

materiali: materials: **A00 A01 A02 A04**

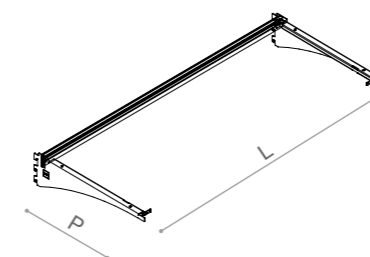

	P	L 70	L 100	L 120
		codice code	codice code	codice code
	26	7089645	7089650	7089655
	36	7089660	7089665	7089670
	46	7089675	7089680	7089685

6 Lampada led per ripiani luminosi legno/vetro
Led lamp for wooden and glass lit shelves

materiali: materials: **Z00**

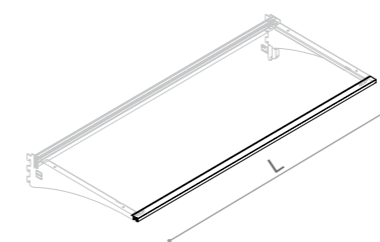

L. 70 - 2 led da 8 W
L. 100 - 2 led da 11,5 W
L. 120 - 2 led da 14 W
L.70 - 2 led lamps by 8 W
L.100 - 2 led lamps by 11,5 W
L.120 - 2 led lamps by 14 W

L'elettrificazione dei ripiani luminosi non è compatibile con i pannelli dogati legno.
The electrification of the lit shelves is incompatible with the wooden slatted panels.

	L	codice code
	70	7089690
	100	7089695
	120	7089700



7 Ripiano legno per montante asolato
Wooden shelf for slotted upright

materiali: materials: **B00 B01 B02 B03 B04**

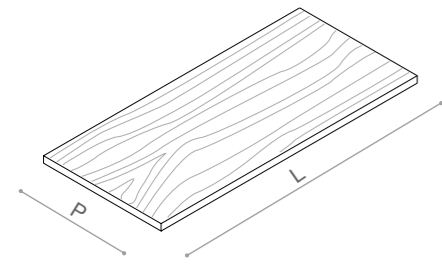

P	L 70	L 100	L 120
	codice code	codice code	codice code
26	7089705	7089710	7089715
36	7089720	7089725	7089730
46	7089735	7089740	7089745

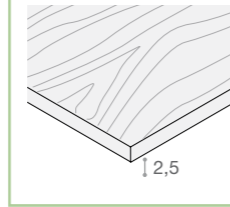

10 Greca posteriore per ripiani legno
Wire back stopper for wooden shelves

materiali: materials: **G00**

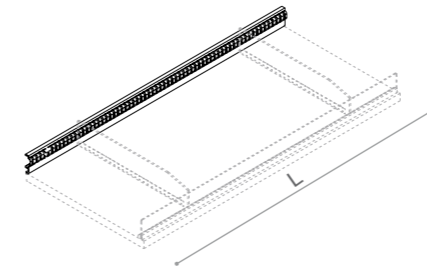

L	codice code
70	7069455
100	7069460
120	7069465

8 Ripiano legno con canalino per montante asolato
Wooden shelf with groove for slotted upright

materiali: materials: **B00 B01 B02 B03 B04**

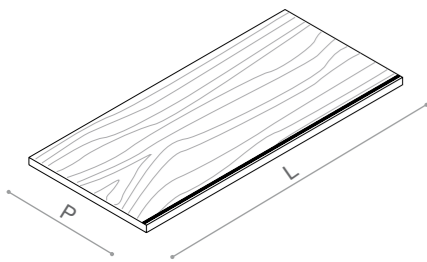

P	L 70	L 100	L 120
	codice code	codice code	codice code
26	7089750	7089755	7089760
36	7089765	7089770	7089775
46	7089780	7089785	7089790

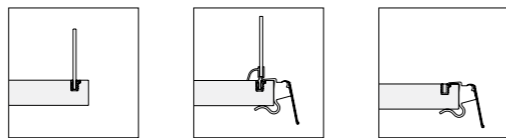
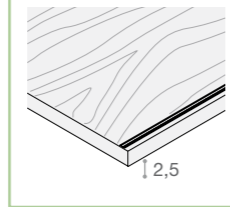

11 Kit spondina anteriore acrilico per ripiani legno
Acrylic front stopper set for wooden shelves

materiali: materials: **F00**

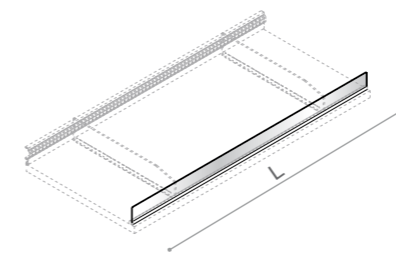

solo colore K0
K0 colour only

L	codice code
70	7069475
100	7069480
120	7069485

12 Divisorio acrilico per ripiani metallo/legno
Acrylic divider for metal/wooden shelves

materiali: materials: **F00**

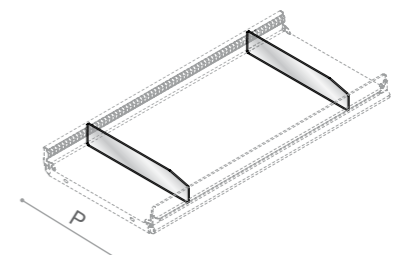

P	codice code
26	7089795
36	7069495
46	7069500

solo colore K0
K0 colour only

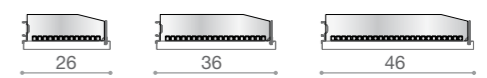

I divisorii in acrilico richiedono l'utilizzo della greca posteriore di supporto e del kit spondina anteriore in acrilico.

The acrylic dividers require the use of the wire back stopper and of the acrylic front stopper set.

9 Spondina anteriore acrilico per ripiani legno
Acrylic front stopper for wooden shelves

materiali: materials: **F00**

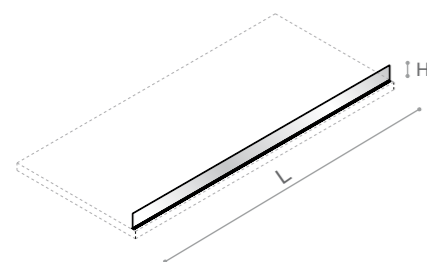

solo colore K0
K0 colour only

H	L 70	L 100	L 120
	codice code	codice code	codice code
2	7069435	7069437	7069440
6	7069445	7069447	7069450

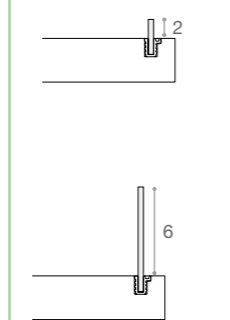

13 Portaprezzo regolabile per ripiani legno
Wooden shelves adjustable price holder

materiali: materials: **Z00**

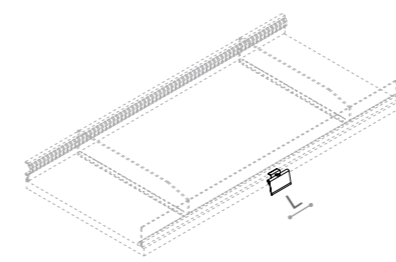

L	codice code
7	7069510

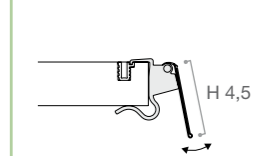

14 Ripiano vetro per montante asolato
Glass shelf for slotted upright

materiali: materials: **E00** **E01** **E02**

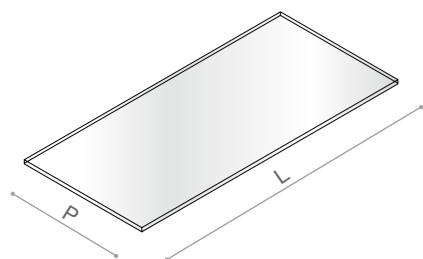

	P	L 70	L 100	L 120
		codice code	codice code	codice code
	26	7089800	7089805	7089810
	36	7070255	7070260	7070265
	46	7070275	7070280	7070285

TEMPERATI / TEMPERED

15 Ripiano vetro con canalino per montante asolato
Glass shelf with groove for slotted upright

materiali: materials: **E00** **E01** **E02**

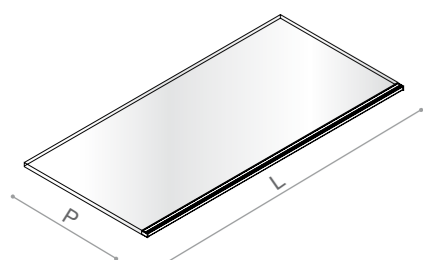

	P	L 70	L 100	L 120
		codice code	codice code	codice code
	26	7089815	7089820	7089825
	36	7070495	7070500	7070505
	46	7070515	7070520	7070525

TEMPERATI / TEMPERED

16 Spondina anteriore acrilico per ripiani vetro
Acrylic front stopper for glass shelves

materiali: materials: **F00**

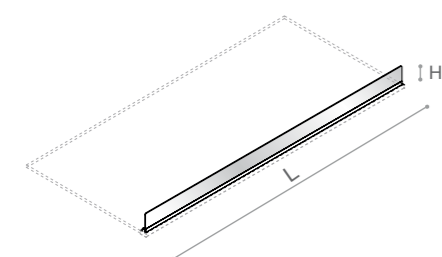

	H	L 70	L 100	L 120
		codice code	codice code	codice code
	2	7069435	7069437	7069440
	6	7069445	7069447	7069450

Solo colore K0
K0 colour only

17 Greca posteriore per ripiani vetro
Wire back stopper for glass shelves

materiali: materials: **G00**

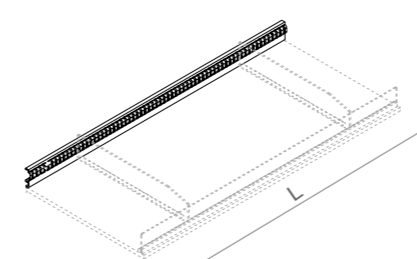

	L	codice code
	70	7069455
	100	7069460
	120	7069465

18 Kit spondina anteriore acrilico per ripiani vetro
Acrylic front stopper set for glass shelves

materiali: materials: **F00**

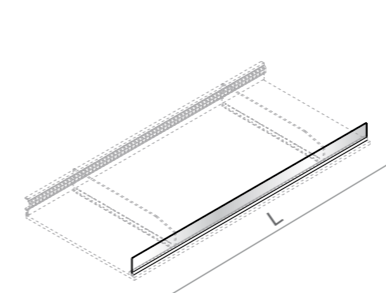

	L	codice code
	70	7069475
	100	7069480
	120	7069485

Solo colore K0
K0 colour only

19 Divisorio acrilico per ripiani metallo/vetro
Acrylic divider for metal/glass shelves

materiali: materials: **F00**

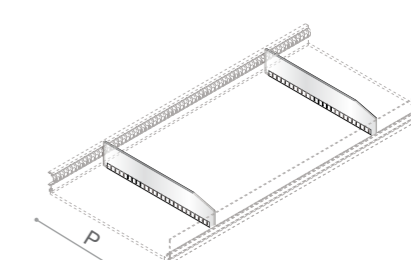

P	codice code
26	7089795
36	7069495
46	7069500

solo colore K0
K0 colour only

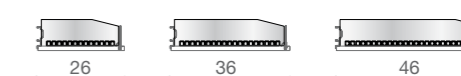

I divisorio in acrilico richiedono l'utilizzo della greca posteriore di supporto e del kit spondina anteriore in acrilico.

The acrylic dividers require the use of the wire back stopper and of the acrylic front stopper set.

20 Portaprezzo regolabile per ripiani vetro
Glass shelves adjustable price holder

materiali: materials: **Z00**

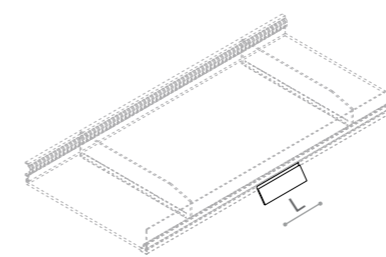

	L	codice code
	7	7070635

21 Ripiano angolo interno 45° legno
 Wooden 45° inward corner shelf

materiali: materials: **B00 B01 B02 B03 B04**

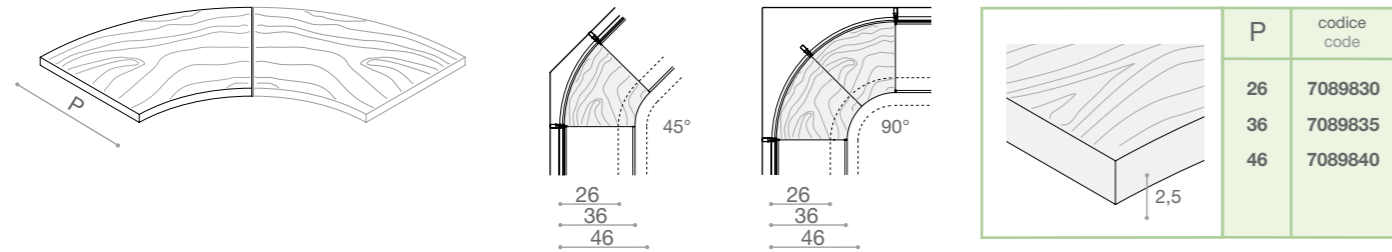

22 Ripiano angolo interno 45° vetro
 Glass 45° inward corner shelf

materiali: materials: **E00 E01 E02**

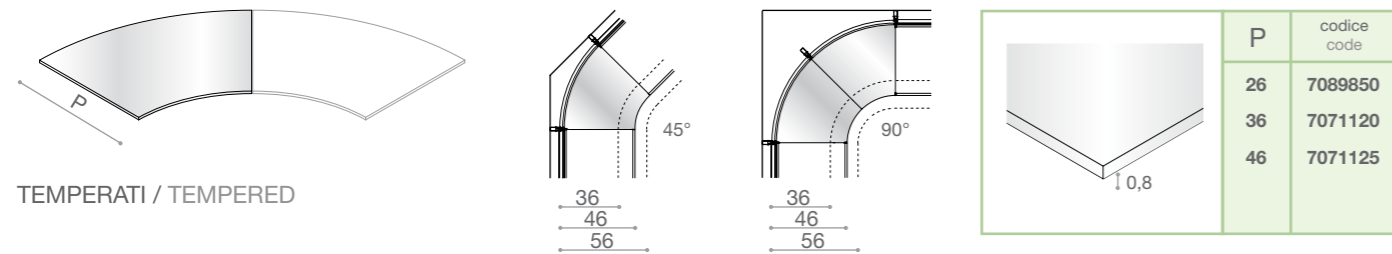

23 Ripiano angolo esterno 90° legno
 Wooden 90° outward corner shelf

materiali: materials: **B00 B01 B02 B03 B04**

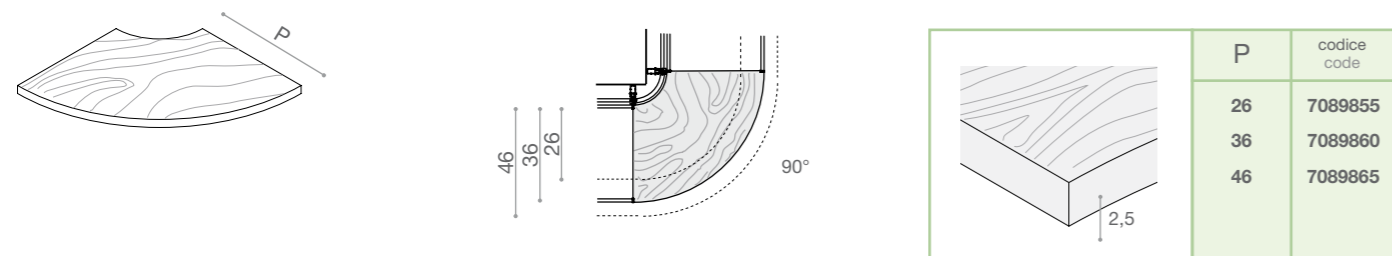

24 Ripiano angolo esterno 90° vetro
 Glass 90° outward corner shelf

materiali: materials: **E00 E01 E02**

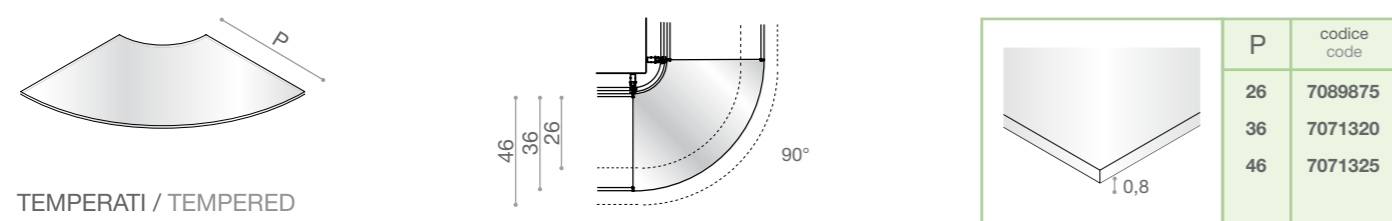

25 Piedino angolo esterno
 Outward corner foot

materiali: materials: **A00***



*COLORE UNICO verniciatura a polvere colore nero 03T.
 *ONE COLOUR ONLY powder coating black 03T.

codice code
7071180

26 Batticarrello base scatolata
 Box-shaped base trolley bumper

materiali: materials: **CR0**

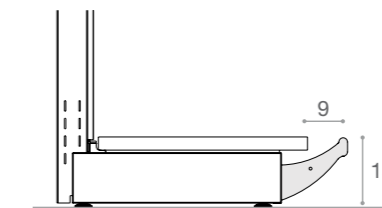
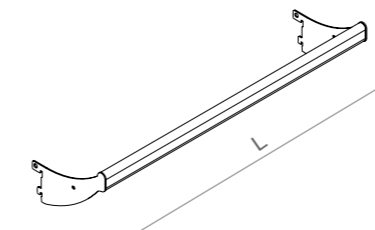

L	codice code
70	7069945
100	7069950
120	7069955

27 Batticarrello angolo esterno 90° base scatolata
 90° outward corner trolley bumper for box-shaped base

materiali: materials: **CR0**

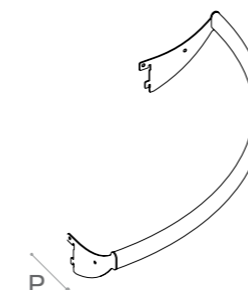

P	codice code
36	7090080
46	7089200
56	7089205

28 Coppia reggipiano doga per ripiani legno/vetro
Shelf supports for slatted panels (pair) - wooden/glass shelves

materiali: materials: **A00 A01 A02 A04**

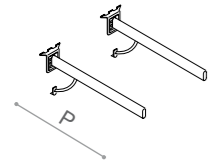

	P	codice code
	30	7075870

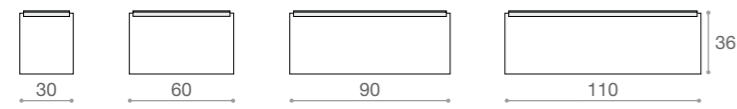

	L 30	L 60	L 90	L 110
	20	25	30	35

> CARICO CONSIGLIATO UNIFORMEMENTE DISTRIBUITO
> UNIFORMLY DISTRIBUTED RECOMMENDED LOAD

29 Profilo reggipiano singolo doga per ripiani legno/vetro
Single shelf support profile for slatted panels - wooden/glass shelves

materiali: materials: **G00**

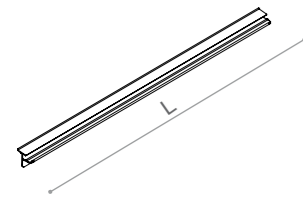

	L	codice code
	30	7075875
	60	7075880
	90	7075885
110	7075890	

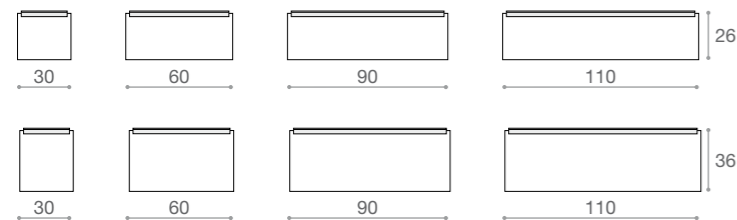

	L 30	L 60	L 90	L 110
	20	25	30	35
	15	20	30	35

> CARICO CONSIGLIATO UNIFORMEMENTE DISTRIBUITO
> UNIFORMLY DISTRIBUTED RECOMMENDED LOAD

30 Ripiano legno per pannello dogato
Wooden shelf for slatted panel

materiali: materials: **B00 B01 B02 B03 B04**

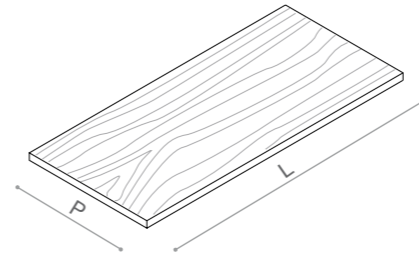

	P	L 30 codice code	L 60 codice code	L 90 codice code	L 110 codice code
	26	7075895	7075900	7075905	7075910
36	7075915	7075920	7075925	7075930	

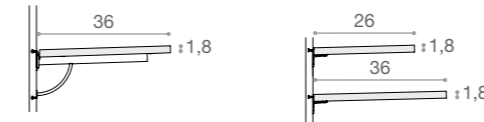

31 Ripiano vetro per pannello dogato
Glass shelf for slatted panel

materiali: materials: **E00 E01 E02**

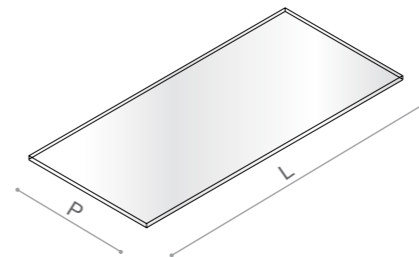

	P	L 30 codice code	L 60 codice code	L 90 codice code	L 110 codice code
	26	7076015	7076020	7076025	7076030
36	7076035	7076040	7076045	7076050	

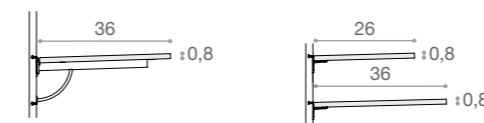

32 Barra frontale super
Super front bar

materiali: materials: **G00**

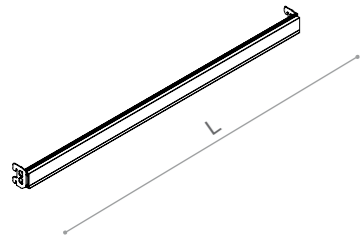

I supporti della barra vengono forniti esclusivamente nel colore grigio 13P
The bar supports are supplied in colour grey 13P only

L	codice code
70	7069515
100	7069520
120	7069525

33 Barra frontale maxi
Maxi front bar

materiali: materials: **G00**

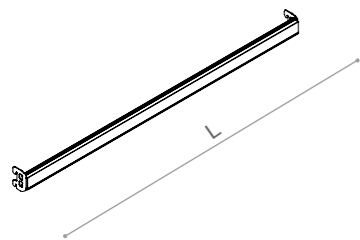

I supporti della barra vengono forniti esclusivamente nel colore grigio 13P
The bar supports are supplied in colour grey 13P only

L	codice code
70	7076095
100	7076100
120	7076105

34 Blister filo singolo
Single wire blister

materiali: materials: **A00 A01 A02 A04 CR0**

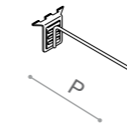

Ø	P	codice code
Ø 4	14	7078390
	18	7078395
Ø 6	24	7078400
	30	7078405
	36	7078410

35 Blister filo singolo con portaprezzo
Single wire blister with price holder

materiali: materials: **A00 A01 A02 A04 CR0**

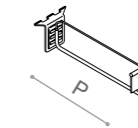

Ø	P	codice code
Ø 4	14	7078425
	18	7078430
Ø 6	24	7078435
	30	7078440
	36	7078445

36 Blister filo doppio
Double wire blister

materiali: materials: **A00 A01 A02 A04 CR0**

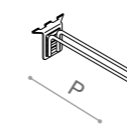

Ø	P	codice code
Ø 4	18	7078460
	24	7078465
	30	7078470

37 Blister filo doppio con portaprezzo
Double wire blister with price holder

materiali: materials: **A00 A01 A02 A04 CR0**

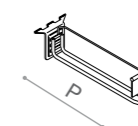

Ø	P	codice code
Ø 4	18	7078475
	24	7078480
	30	7078485

38 Gancio semplice
Hook blister

materiali: materials: **A00 A01 A02 A04 CR0**



codice code
7078650

**FISSAGGIO BARRA
BAR FIXING**

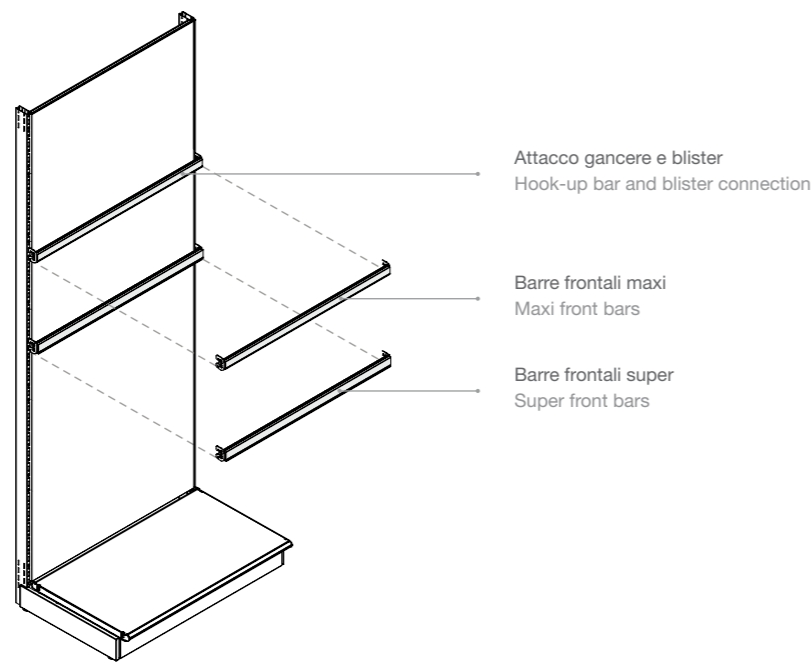

**FISSAGGIO BLISTER SU PANNELLI DOGATI E BARRA
FIXING OF BLISTERS ON SLATTED PANELS AND BAR**

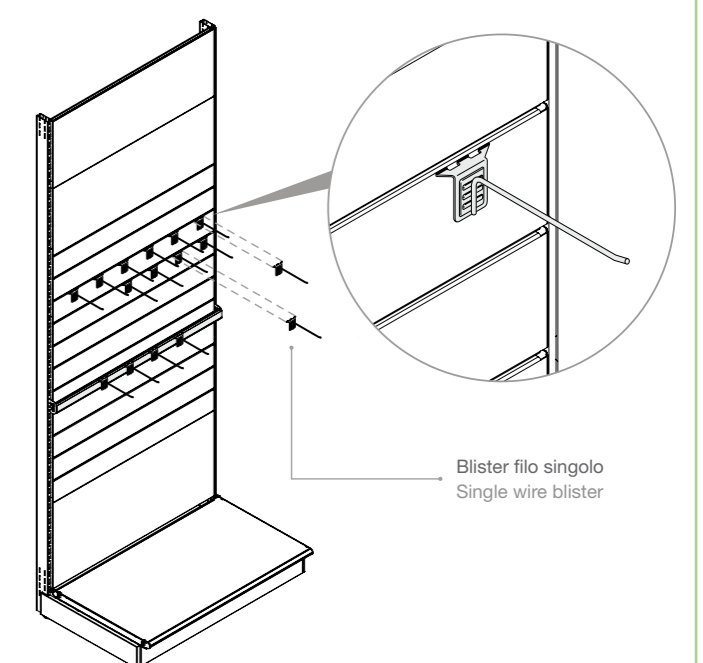

39 Blister filo singolo per pannello dogato
Single wire blister for slatted panel

materiali: materials: **A00 A01 A02 A04 CR0**

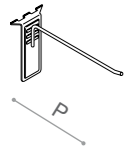

Ø	P	codice code	
		P	codice code
Ø 6	18	18	7078490
	24	24	7078495
Ø 8	30	30	7078500

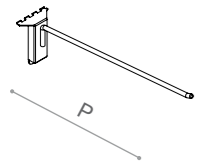

Ø	P	codice code	
		P	codice code
Ø 10	36	36	7078505
	46	46	7078510

40 Blister filo singolo con portaprezzo per pannello dogato
Single wire blister with price holder for slatted panel

materiali: materials: **A00 A01 A02 A04 CR0**

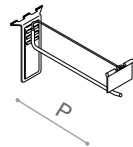

Ø	P	codice code	
		P	codice code
Ø 6	18	18	7078515
	24	24	7078520
Ø 8	30	30	7078525

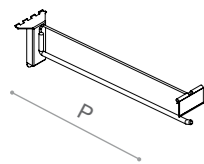

Ø	P	codice code	
		P	codice code
Ø 10	36	36	7078530
	46	46	7078535

41 Blister filo doppio per pannello dogato
Double wire blister for slatted panel

materiali: materials: **A00 A01 A02 A04 CR0**

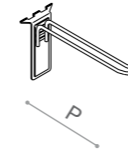

Ø	P	codice code	
		P	codice code
Ø 5	18	18	7078540
	24	24	7078545
	30	30	7078550

42 Blister filo doppio con portaprezzo per pannello dogato
Double wire blister with price holder for slatted panel

materiali: materials: **A00 A01 A02 A04 CR0**

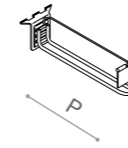

Ø	P	codice code	
		P	codice code
Ø 5	18	18	7078555
	24	24	7078560
	30	30	7078565

**FISSAGGIO BLISTER SU PANNELLI DOGATI
FIXING OF BLISTERS ON SLATTED PANELS**

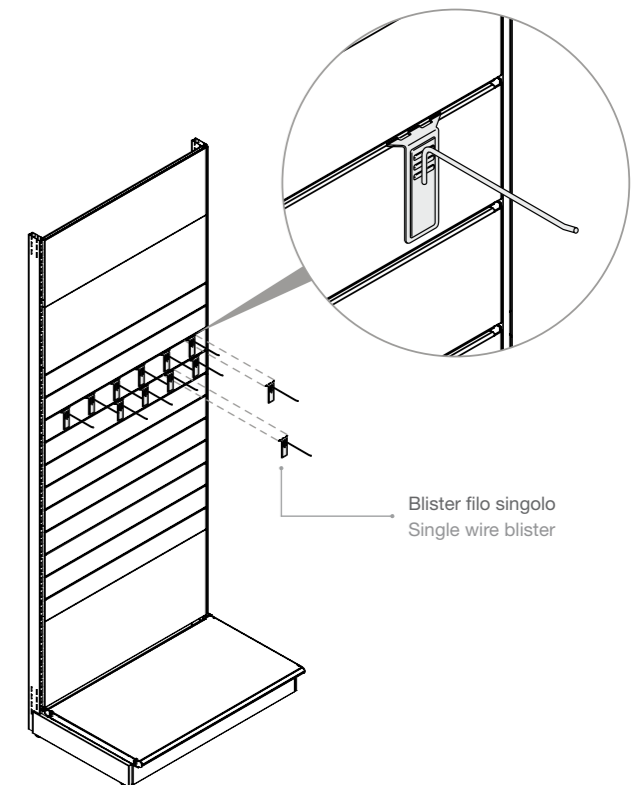

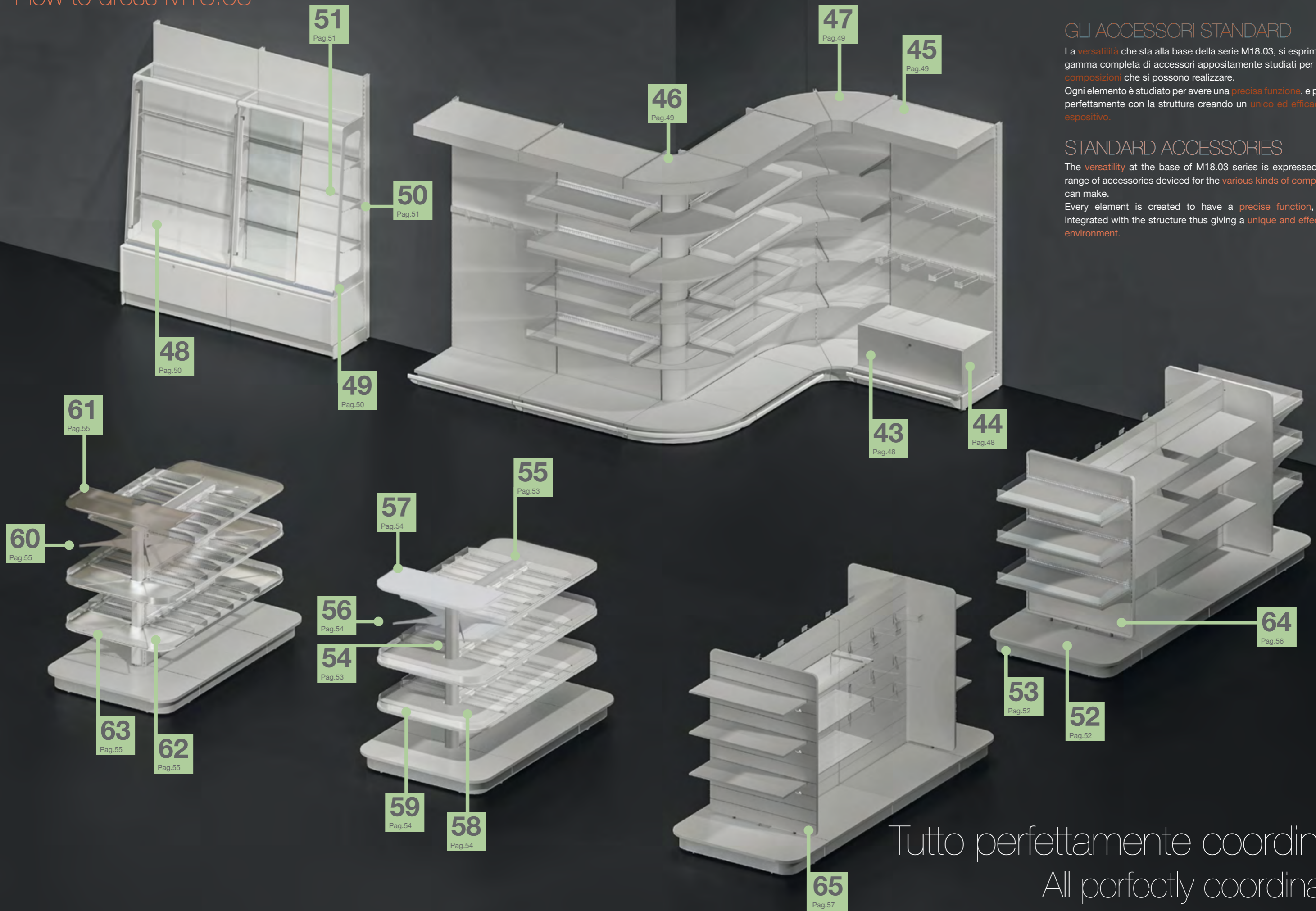

GLI ACCESSORI STANDARD

La **versatilità** che sta alla base della serie M18.03, si esprime grazie alla gamma completa di accessori appositamente studiati per le **molteplici composizioni** che si possono realizzare. Ogni elemento è studiato per avere una **precisa funzione**, e per integrarsi perfettamente con la struttura creando un **unico ed efficace ambiente espositivo**.

STANDARD ACCESSORIES

The **versatility** at the base of M18.03 series is expressed also into a range of accessories devised for the **various kinds of compositions** one can make. Every element is created to have a **precise function**, and to be integrated with the structure thus giving a **unique and effective display environment**.

Tutto perfettamente coordinato
All perfectly coordinated

43 Mobiletto base scatolata
Base box for rectangular foot

materiali: materials: **B00 B01 B02 B03 B04**

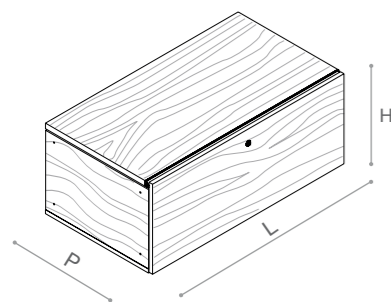

	P	H	L	codice code
	46	36	70	7090050
	46	36	100	7090055
	46	36	120	7090060

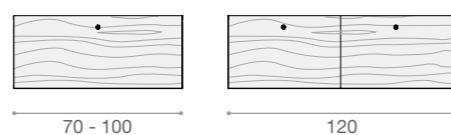

43.1 Spondina aggiuntiva
Additional drawer side

materiali: materials: **F01**

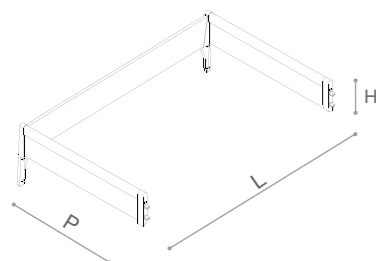

	P	H	L	codice code
	46	9	70	7083004
	46	9	100	7083006
	46	9	120	7083013

44 Fianchi mobiletto di base
Base box side panels

materiali: materials: **C00 C01**

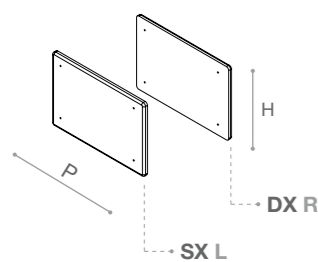

	P	H	codice code
SX L	46	36	7090065
DX R	46	36	7090085

45 Veletta V01 diritta
V01 straight canopy

materiali: materials: **B00 B01 B02**

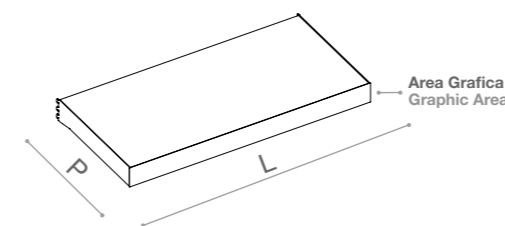

Importante:
LA GRAFICA NON È FORNITA.
Important:
THE GRAPHIC IS NOT PROVIDED.

dimensioni dimensions	L 70	L 100	L 120
codice code	7089320	7089325	7089330
P 46	7089340	7089345	7089350
P 56			
Area Grafica LxH Graphic Area LxH	cm	cm	cm
	69,8x10	99,8x10	119,8x10

I reggipiani e la fascia frontale vengono forniti esclusivamente in A00 e A01
The shelf supports and the front frame are supplied in A00 and A01 only

46 Veletta V01 angolo esterno 90°
V01 90° outward corner canopy

materiali: materials: **B00 B01 B02**

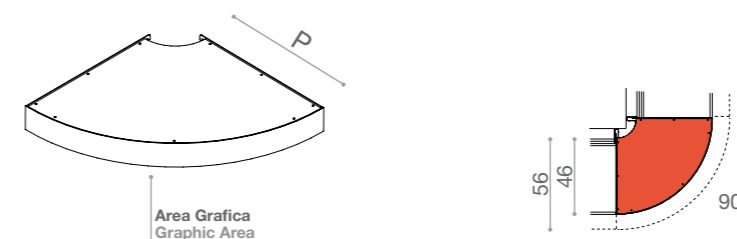

Importante:
LA GRAFICA NON È FORNITA.
Important:
THE GRAPHIC IS NOT PROVIDED.

dimensioni dimensions	P 46	P 56
codice code	7089360	7089365
Area Grafica LxH Graphic Area LxH	cm	cm
	85,6x10	100,5x10

I reggipiani e la fascia frontale vengono forniti esclusivamente in A00 e A01
The shelf supports and the front frame are supplied in A00 and A01 only

47 Veletta V01 angolo interno 45°
V01 45° inward corner canopy

materiali: materials: **B00 B01 B02**

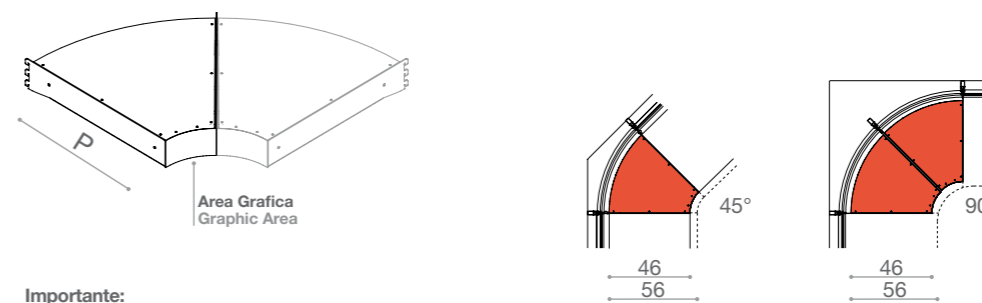

Importante:
LA GRAFICA NON È FORNITA.
Important:
THE GRAPHIC IS NOT PROVIDED.

dimensioni dimensions	P 46	P 56
codice code	7089370	7089375
Area Grafica LxH Graphic Area LxH	cm	cm
	25,3x10	17x10

I reggipiani e la fascia frontale vengono forniti esclusivamente in A00 e A01
The shelf supports and the front frame are supplied in A00 and A01 only

48 Vetrina V01
V01 Glass cabinet

LED
4000° K

materiali: materials: **A00 A01 A02 A04**

Scorrevole anti estrazione
Extraction-proof sliding panel

Serratura a pulsante
Lock with button

P	H	L	codice code
46	96	100	7073420
46	96	120	7073425
46	124	100	7073435
46	124	120	7073440
46	144	100	7073450
46	144	120	7073455

H.96 - 2 led da 7,2 W
H.124 - 2 led da 10,8 W
H.144 - 2 led da 14,5 W

H.96 - 2 led lamps by 7,2 W
H.124 - 2 led lamps by 10,8 W
H.144 - 2 led lamps by 14,5 W

49 Fianchi vetrina V01
V01 Glass cabinet sides

materiali: materials: **E00**

I fianchi sono di colore grigio
The sides are in grey colour

P	H 96	H 124	H 144
	SX L	SX L	SX L
46	7073510	7073515	7073520

P	H 96	H 124	H 144
	DX R	DX R	DX R
46	7073645	7073650	7073655

Più vetrine affiancate richiedono l'aggiunta di 1 solo fianco destro e di 1 solo fianco sinistro.
Several consecutive glass cabinets require 1 right and 1 left side panel only.

50 Coppia reggipiano per ripiani vetrina V01
V01 Glass cabinet shelf supports - pair

materiali: materials: **A00 A01 A02 A04**

P	L	codice code
20	70	7090200
20	100	7090205
20	120	7090210

51 Ripiano vetro per vetrina V01
V01 Glass cabinet glass shelf

materiali: materials: **E00**

trasparente
transparent

P	L 70	L 100	L 120
	codice code	codice code	codice code
20	7099500	7073555	7073560
23	7099506	7073570	7073575
25	7099502	7073585	7073590
30	7090220	7073600	7073605

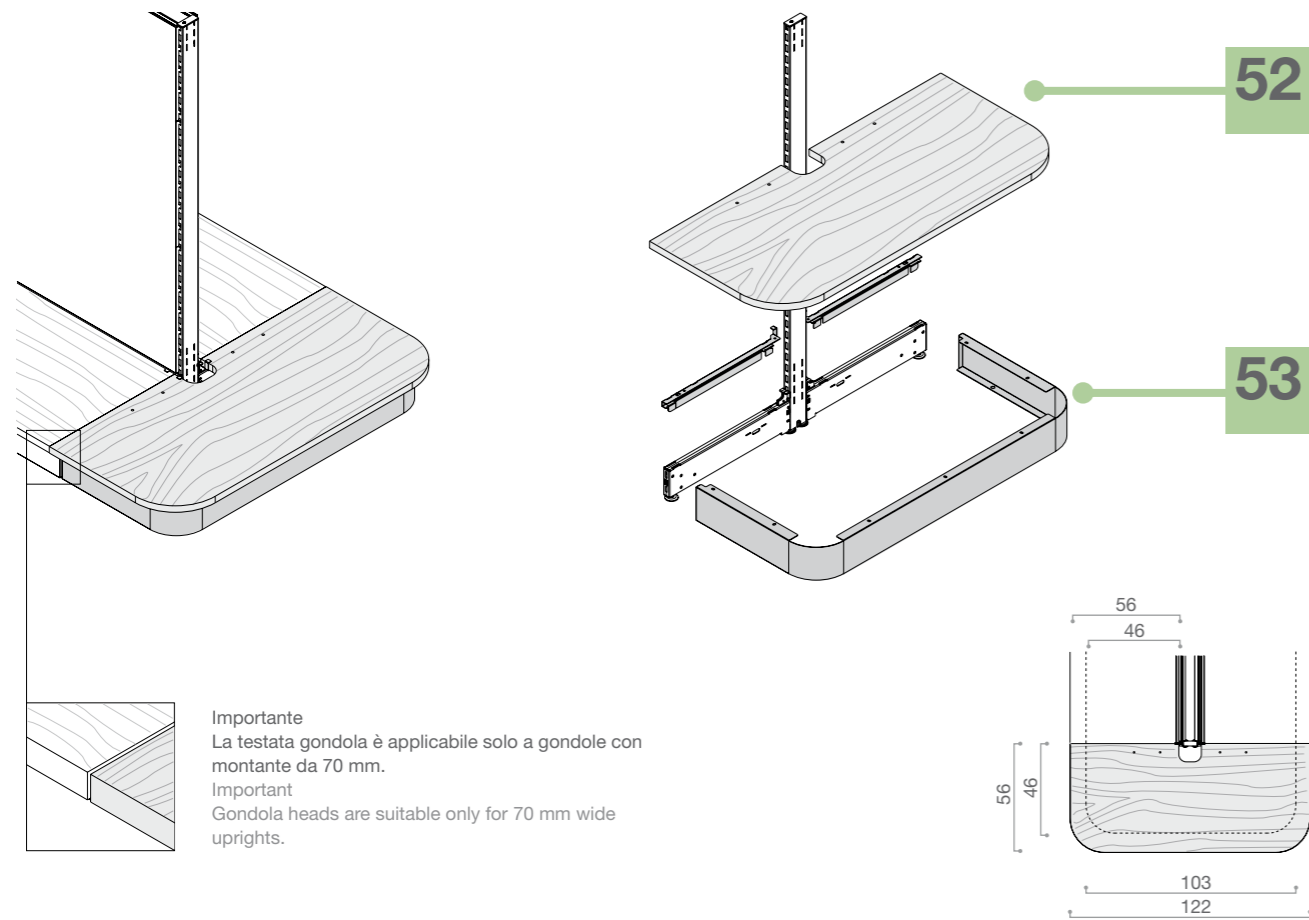

52 Ripiano base testata gondola
Gondola head base shelf

materiali: materials: **B00 B01 B02 B03 B04**

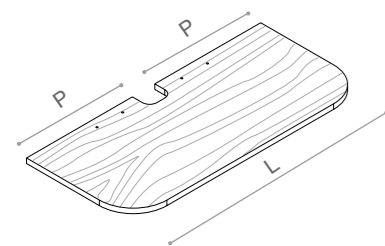

P	L	codice code
36	84	7099507
46	103	7089910
56	122	7089915

53 Kit zoccolo ripiano base testata gondola
Gondola head base skirting set

materiali: materials: **A00 A01 A02 A04**

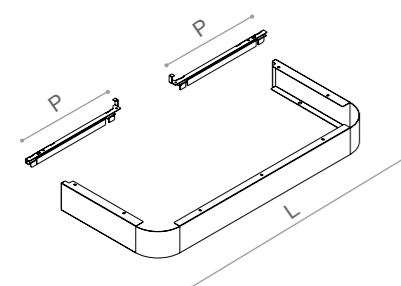

P	L	codice code
36	74	7099508
46	93	7089920
56	112	7089925

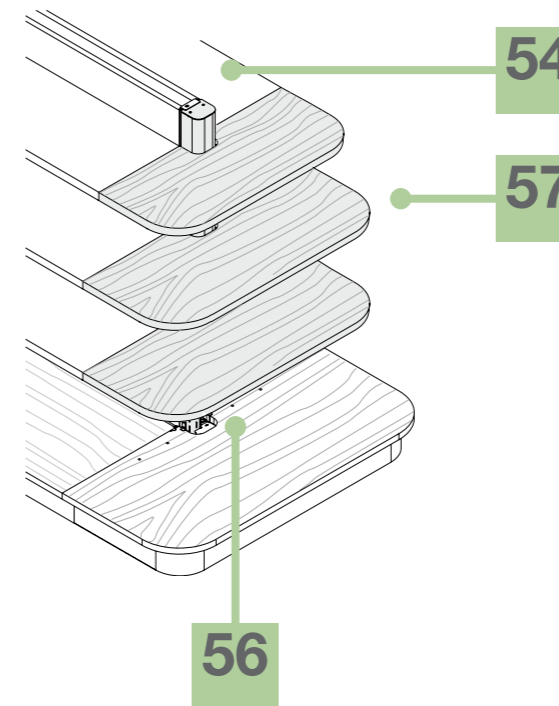

54 Montante ripiani testata gondola
Gondola head shelves upright

materiali: materials: **A00 A01 A02 A04**



H	codice code
134	7089475
146	7089480
158	7089485

55 Chiusura superiore gondola
Gondola top cover

materiali: materials: **A00 A01 A02 A04**

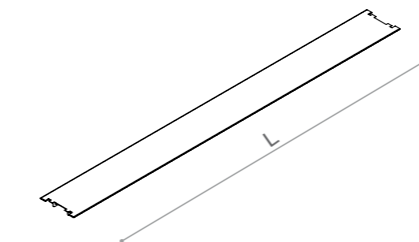

L	codice code
70	7069905
100	7069910
120	7069915

56 Kit reggipiano per ripiani legno testata gondola
Gondola head wooden shelf support set

materiali: materials: **A00** **A01** **A02** **A04**

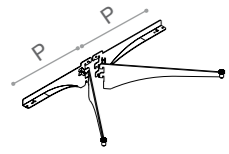

P	codice code
26	7089930
36	7089935
46	7089940

57 Ripiano legno testata gondola
Gondola head wooden shelf

materiali: materials: **B00** **B01** **B02** **B03** **B04**

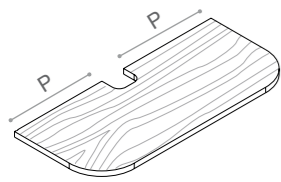

P	codice code
26	7089945
36	7089950
46	7089955

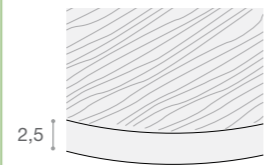

60 Kit reggipiano per ripiani vetro testata gondola
Gondola head glass shelf support set

materiali: materials: **A00** **A01** **A02** **A04**

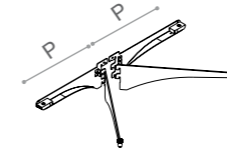

P	codice code
26	7089985
36	7089990
46	7089995

61 Ripiano vetro testata gondola
Gondola head glass shelf

materiali: materials: **E00** **E01** **E02**

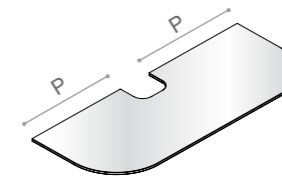

P	codice code
26	7090005
36	7072420
46	7072425

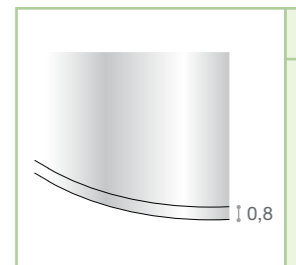

58 Ripiano legno con canalino testata gondola
Gondola head wooden shelf with groove

materiali: materials: **B00** **B01** **B02** **B03** **B04**

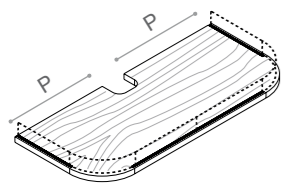

P	codice code
26	7089960
36	7089965
46	7089970

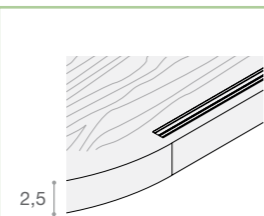

62 Ripiano vetro con canalino testata gondola
Gondola head glass shelf with groove

materiali: materials: **E00** **E01** **E02**

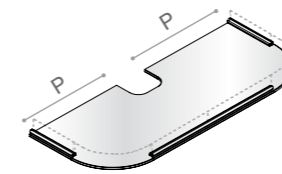

P	codice code
26	7090010
36	7072480
46	7072485

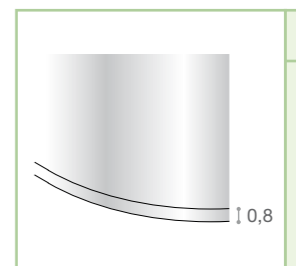

59 Spondina acrilico ripiano legno con canalino testata gondola
Gondola head wooden shelf with groove acrylic front stopper

materiali: materials: **F00**

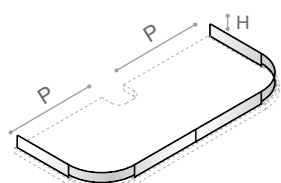

solo colore K0
K0 colour only

P	H 2	
	codice code	
26	7089975	
36	7072345	
46	7072350	

P	H 6	
	codice code	
26	7089980	
36	7072360	
46	7072365	

63 Spondina acrilico ripiano vetro con canalino testata gondola
Gondola head glass shelf with groove acrylic front stopper

materiali: materials: **F00**

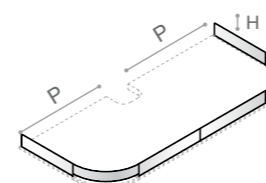

solo colore K0
K0 colour only

P	H 2	
	codice code	
26	7090015	
36	7072510	
46	7072515	

P	H 6	
	codice code	
26	7090020	
36	7072525	
46	7072530	

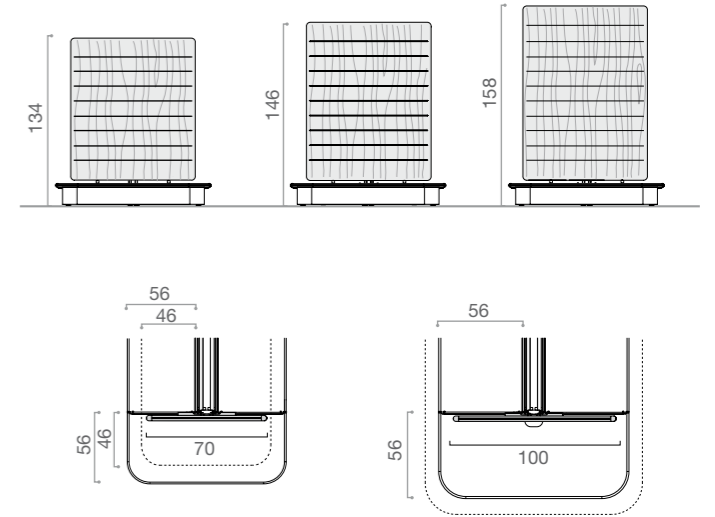
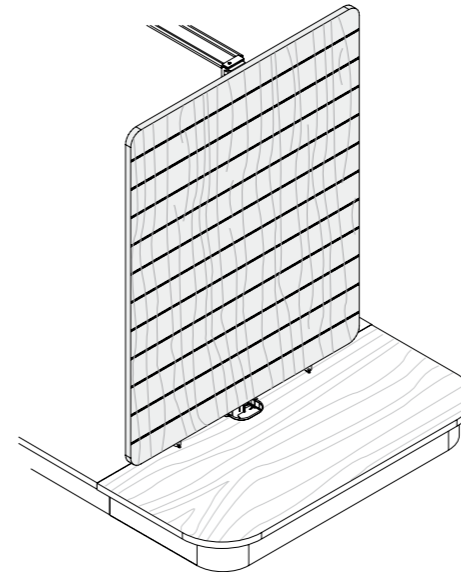
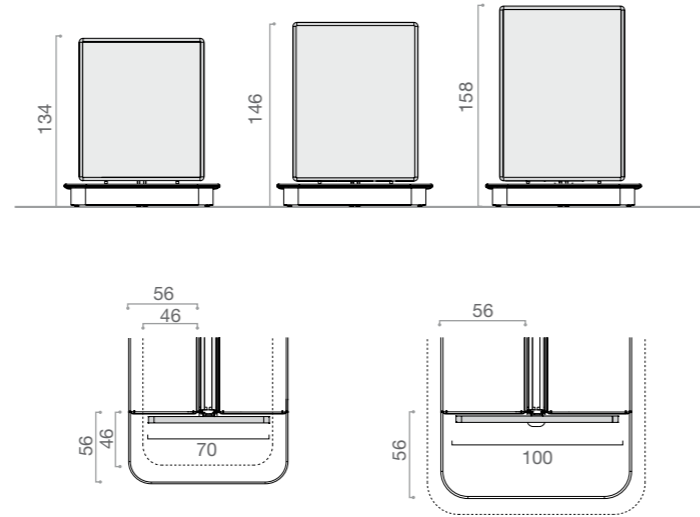
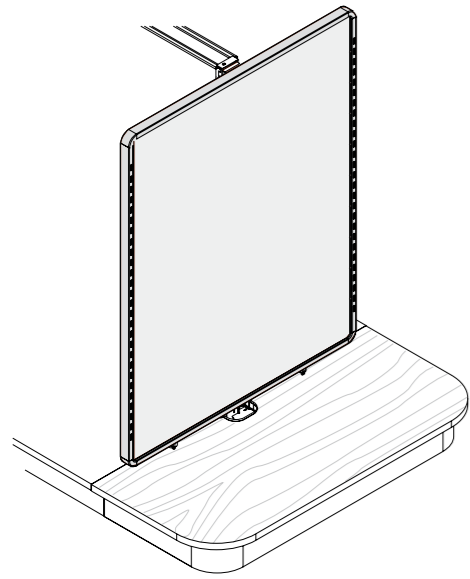

64 Kit pannello cremagliere verticali testata gondola su ripiano base
 Gondola head lateral uprights panel set on base shelf
 materiali: materials: **B00 B01 B02 B03 B04**

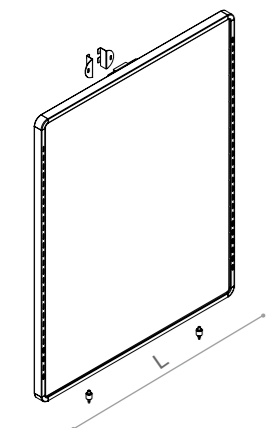

H	L 70	L 100
	codice code	codice code
134	7072115	7072120
146	7072125	7072130
158	7072135	7072140

A00 A01 A02 A04

65 Kit pannello dogato testata gondola su ripiano base
 Gondola head slatted panel set on base shelf
 materiali: materials: **B00 B01 B02 B03 B04**

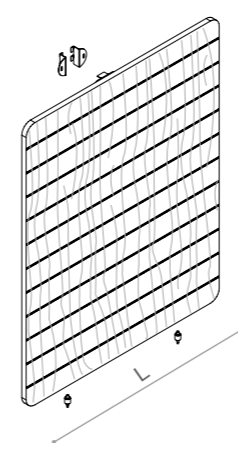

H	L 70	L 100
	codice code	codice code
134	7089880	7089885
146	7089890	7089895
158	7089900	7089905

A00 A01 A02 A04

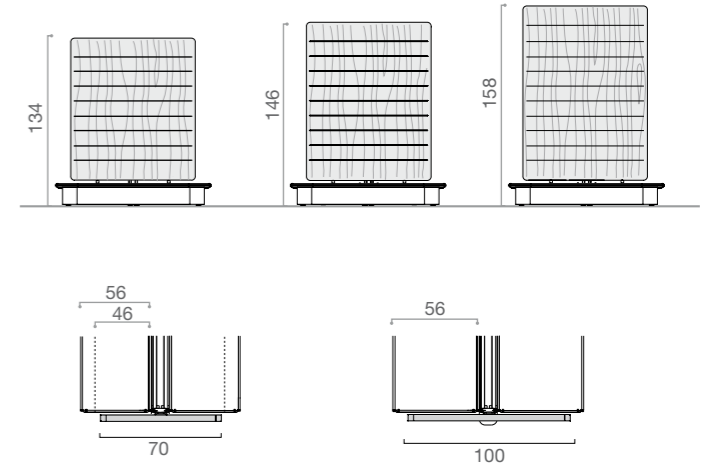
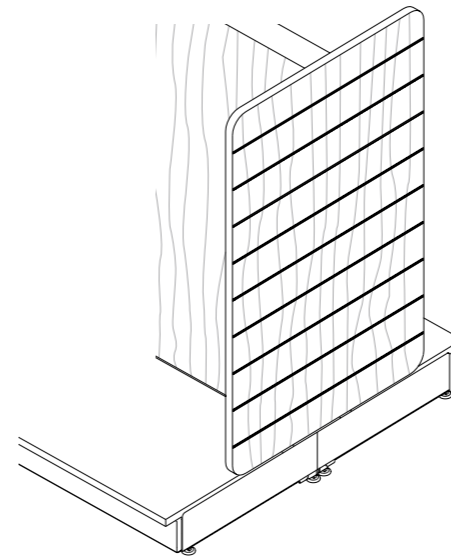
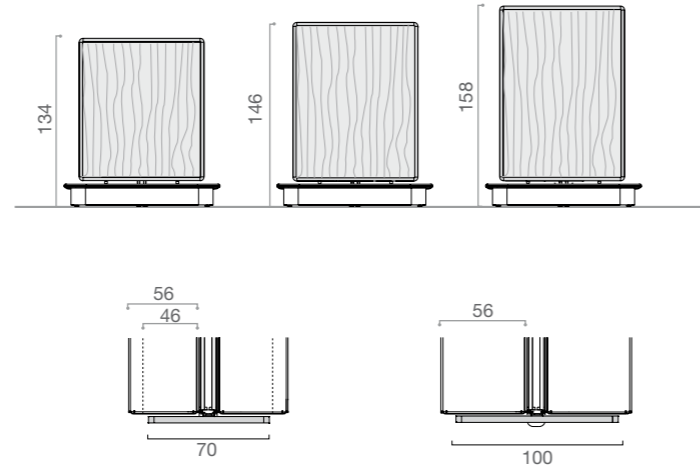
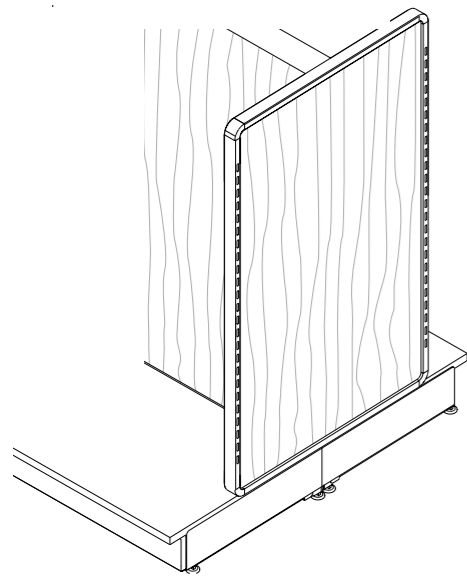

66

Kit pannello cremagliere verticali testata gondola senza ripiano base
Gondola head lateral uprights panel set without base shelf

materiali: materials: B00 B01 B02 B03 B04

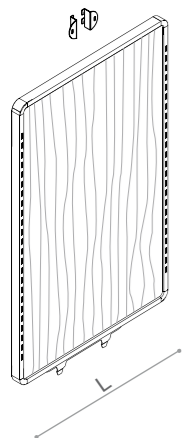

H	L 70	L 100
	codice code	codice code
134	7099510	7099511
146	7099512	7099513
158	7099514	7099515

67

Kit pannello dogato testata gondola senza ripiano base
Gondola head slatted panel set without base shelf

materiali: materials: B00 B01 B02 B03 B04

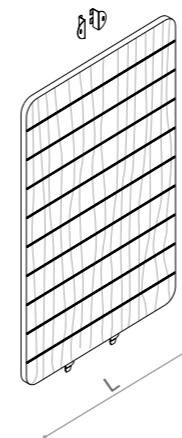

H	L 70	L 100
	codice code	codice code
134	7099516	7099517
146	7099518	7099519
158	7099520	7099521

Xylo

M18.03

stampato in Italia
printed in Italy

© Gibam Shops spa-unipersonale

Gennaio 2022
January 2022

direzione artistica Anidride Design
art direction Anidride Design

design Gibam Shops spa-unipersonale
design Gibam Shops spa-unipersonale

è vietata la riproduzione totale o parziale del catalogo
senza previa autorizzazione di Gibam Shops spa-unipersonale.
this catalogue cannot be partially or totally reproduced unless
Gibam Shops spa-unipersonale has granted permission to do so.



GIBAM

composit

100%
MADE IN ITALY

GIBAM SHOPS spa - unipersonale

Via VIII Strada, 13
61032 Bellocchi di Fano (PU)
ITALIA
tel.: +39 0721 85991

www.gibamcomposit.com
marketing@gibamcomposit.com

XT0M1803